

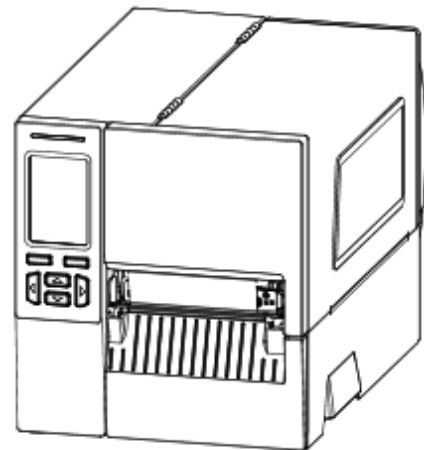

Fastmark M9XPd
Thermal Barcode Printer
(Direct & Transfer)

User's Guide



Copyright Information

©2024 AMT Datasouth Corp.

Information in this manual is subject to change without notice and does not represent a commitment on the part of AMT Datasouth Corporation. No part of this manual may be reproduced or transmitted in any form by any means, for any purpose other than the purchaser's personal use, without the expressed written permission of AMT Datasouth Corporation.

CG Triumvirate is a trademark of Agfa Corporation. CG Triumvirate Bold Condensed font is under license from the Monotype Corporation. Windows is a registered trademark of Microsoft Corporation.

All other trademarks are the property of their respective owners.

Agency Compliance and Approvals



EN 55032, Class A
EN 55035
EN 301489-1,-17
EN 300 328
EN 62311
EN 60950-1

This is a class A product. In a domestic environment this product may cause radio interference in which case the user may be required to take adequate measures.

FCC part 15B, Class A

ICES-003, Class A

This equipment has been tested and found to comply with the limits for a Class A digital device, pursuant to Part 15 of the FCC Rules. These limits are designed to provide reasonable protection against harmful interference when the equipment is operated in a commercial environment.

This equipment generates, uses, and can radiate radio frequency energy and, if not installed and used in accordance with the manufacturer's instruction manual, may cause harmful interference with radio communications. Operation of this equipment in a residential area is likely to cause harmful interference, in which case you will be required to correct the interference at your own expense.



This Class A digital apparatus complies with Canadian ICES-003.

Cet appareil numérique de la classe A est conforme à la norme NMB-003 du Canada.

This device complies with Part 15 of the FCC Rules. Operation is subject to the following two conditions: (1) This device may cause harmful interference, and (2) this device must accept any interference received, including interference that may cause undesired operation.



AS/NZS CISPR 32, Class A
AS/NZS 4268 & 2772.2



UL 62368-1
CSA C22.2 No. 62368-1



EN 62368-1:2014/A11:2017

GB 4943.1

GB 9254, Class A



GB 17625.1

此为 A 级产品，在生活环境中，该产品可能会造成无线电干扰，在这种情况下，可能需要用户对干扰采取切实可行的措施。



Energy Star for Imaging Equipment Version 3.2



IS 13252(Part 1)/

IEC 60950-1

Note: There may have certification differences in the series models, please refer to product label for accuracy.

Important safety instructions:

1. Read all of these instructions and keep them for later use.
2. Follow all warnings and instructions on the product.
3. Disconnect the power plug from the AC outlet before cleaning or if faults happen.
4. Do not use liquid or aerosol cleaners. Using a damp cloth is suitable for cleaning.
5. The mains socket shall be installed near the equipment and easily accessible.
6. The unit must be protected against moisture.
7. Ensure the stability when installing the device, Tipping or dropping could cause damage.
8. Make sure to follow the correct power rating and power type indicated on marking label provided by manufacture.
9. Please refer to user manual for maximum operating ambient temperature.

WARNING:



Hazardous moving parts, keep fingers and other body parts away.

CAUTION:

(For equipment with RTC (CR2032) battery or rechargeable battery pack)

Risk of explosion if battery is replaced by an incorrect type.

Dispose of used batteries according to the Instructions as below.

1. DO NOT throw the battery in fire.
2. DO NOT short circuit the contacts.

3. DO NOT disassemble the battery.
4. DO NOT throw the battery in municipal waste.
5. The symbol of the crossed out wheeled bin indicates that the battery should not be placed in municipal waste.



The printhead may be hot and could cause severe burns. Allow the printhead to cool.

CE Statement:

This equipment complies with EU radiation exposure limits set forth for an uncontrolled environment. This equipment should be installed and operated with minimum distance 20 cm between the radiator & your body.

All operational modes:

2.4GHz: 802.11b, 802.11g, 802.11n (HT20), 802.11n (HT40)

5GHz: 802.11a,

The frequency, mode and the maximum transmitted power in EU are listed below:

2410 MHz – 2483.5 MHz: 19.88 dBm (EIRP)

5150 MHz – 5250 MHz: 17.51 dBm (EIRP)

2412 MHz – 2480 MHz:60 dBm (EIRP) (Bluetooth)

Requirements in:

AT/BE/BG/CZ/DK/EE/FR/DE/IS/IE/IT/EL/ES/CY/LV/LI/LT/LU/HU/MT/NL/NO/PL/PT/RO/SI/SK/TR/FI/SE/CH/UK/HR. 5150 MHz-5350 MHz is for indoor use only.

5150-5350 MHz for Only indoor use

5470-5725 MHz indoor/outdoor use

Restrictions In AZE

National restrictions information is provided below

Frequency Band	Country	Remark
5150-5350MHz	Azerbaijan	No license needed if used indoor and power not exceeding 30mW
5470-5725MHz		

Hereby, AMT Datasouth Corp. declares that the radio equipment type [Wi-Fi] IEEE 802.11 a/b/g/n is in compliance with Directive 2014/53/EU

RF exposure warning (Wi-Fi)

This equipment must be installed and operated in accordance with provided instructions and must not be co-located or operating in conjunction with any other antenna or transmitter. End-users and installers must be providing with antenna installation instructions and transmitter operating conditions for satisfying RF exposure compliance.

SAR Value: 0.736 W/kg

RF exposure warning (For Bluetooth)

The equipment complies with FCC RF exposure limits set forth for an uncontrolled environment.

The equipment must not be co-located or operating in conjunction with any other antenna or transmitter.

Canada, Industry Canada (IC) Notices

This Class B digital apparatus complies with Canadian ICES-003 and RSS-210.

Operation is subject to the following two conditions: (1) this device may not cause interference, and (2) this device must accept any interference, including interference that may cause undesired operation of the device.

Radio Frequency (RF) Exposure Information

The radiated output power of the Wireless Device is below the Industry Canada (IC) radio frequency exposure limits. The Wireless Device should be used in such a manner such that the potential for human contact during normal operation is minimized.

This device has been evaluated for and shown compliant with the IC Specific Absorption Rate ("SAR") limits when installed in specific host products operated in portable exposure conditions. **(For Wi-Fi)**

This device has also been evaluated and shown compliant with the IC RF Exposure limits under portable exposure conditions. (Antennas are less than 20 cm from a person's body). **(For Bluetooth)**

Canada, avis de l'Industry Canada (IC)

Cet appareil numérique de classe B est conforme aux normes canadiennes ICES-003 et RSS-210. Son fonctionnement est soumis aux deux conditions suivantes : (1) cet appareil ne doit pas causer d'interférence et (2) cet appareil doit accepter toute interférence, notamment les interférences qui peuvent affecter son fonctionnement.

Informations concernant l'exposition aux fréquences radio (RF)

La puissance de sortie émise par l'appareil sans fil est inférieure à la limite d'exposition aux fréquences radio de l'Industry Canada (IC). Utilisez l'appareil sans fil de façon à minimiser les contacts humains lors du fonctionnement normal.

Ce périphérique a été évalué et démontré conforme aux limites SAR (Specific Absorption Rate – Taux d'absorption spécifique) par l'IC lorsqu'il est connecté à des dispositifs hôtes spécifiques opérant dans des conditions d'utilisation mobile. **(Pour le Wi-Fi)**

Ce périphérique a également été évalué et démontré conforme aux limites d'exposition radio-fréquence par l'IC pour des utilisations par des opérateurs mobiles (les antennes sont à moins de 20 cm du corps d'une personne). **(Pour le Bluetooth)**

NCC 警語:

經型式認證合格之低功率射頻電機，非經許可，公司、商號或使用者均不得擅自變更頻率、加大功率或變更原設計之特性及功能。(即低功率電波輻射性電機管理辦法第十二條)

低功率射頻電機之使用不得影響飛航安全及干擾合法通信；經發現有干擾現象時，應立即停用，並改善至無干擾時方得繼續使用。

前項合法通信，指依電信法規定作業之無線電通信。低功率射頻電機須忍受合法通信或工業、科學及醫療用電波輻射性電機設備之干擾。(即低功率電波輻射性電機管理辦法第十四條)

For MFi Bluetooth



Use of the Made for Apple badge means that an accessory has been designed to connect specifically to the Apple product(s) identified in the badge, and has been certified by the developer to meet Apple performance standards. Apple is not responsible for the operation of this device or its compliance with safety and regulatory standards.

For US Model

Made for iPhone®XS Max, iPhone XS, iPhone XR, iPhone X, iPhone 8, iPhone 8 Plus, iPhone 7, iPhone 7 Plus, iPhone SE, iPhone 6s, iPhone 6s Plus, iPhone 6, iPhone 6 Plus, iPhone 5s, iPad Pro® 12.9-inch (2nd generation), iPad Pro 10.5-inch, iPad® (6th generation), iPad (5th generation), iPad Pro 9.7-inch, iPad Pro 12.9-inch (1st generation), iPad Air® 2, iPad mini™ 4, iPad mini 3, iPad Air, iPad mini 2, iPod touch® (6th generation)

iPad, iPad Air, iPad Pro, iPhone are trademarks of Apple Inc., registered in the U.S. and other countries.



<http://www.amtdatasouth.com/support-1/downloads/>

1. Introduction	1
1.1 Product Introduction	1
1.2 Product Specifications.....	1
2. Operations Overview	4
2.1 Unpacking and Inspection.....	4
2.2 Printer Overview	5
2.3 Operator Control	8
2.4 Web User Interface	11
3. Setup.....	15
3.1 Setting up the Printer.....	15
3.2 Loading the Ribbon.....	16
3.3 Loading the Media.....	17
3.4 Loading the Fanfold/External Media	18
3.5 Loading the Media in Peel-off Mode (Optional).....	18
3.6 Loading the Media in Cutter Mode (Optional).....	20
3.7 Loading the Linerless Media (Optional).....	20
4. Adjustment Knob	22
4.1 Printhead Pressure and Position Adjustment	22
4.2 Ribbon Tension Adjustment Module.....	22
4.3 Mechanism Fine Adjustment to Avoid Ribbon Wrinkles.....	23
5. Diagnostic Tool.....	25
5.1 Start the Diagnostic Tool	25
5.2 Printer Function	26
5.3 Setting Ethernet by Diagnostic Tool.....	27
6.0 LCD Menu Function.....	31
6.1 Enter the Menu	31
6.2 Menu Overview	32
6.3 Setting.....	32

6.4 Sensor	36
6.5 Interface	37
6.6 Advanced	38
6.7 File Manager.....	40
6.8 Diagnostic.....	40
6.9 Favorites (Touch LCD Only)	41
6.10 Linerless Media Printer Configuration.....	42
7.0 Troubleshooting	44
8.0 Maintenance.....	47

1. Introduction

1.1 Product Introduction

Thank you very much for your purchase.

The new high-performance Fastmark M9XPd Series printer was designed to deliver the cleanest and highest quality barcodes. Displays a bifold media door, cutting operational space requirements by 24%. Its all-metal print mechanism guarantees durability in high-volume printing. Engineered for top-notch printing, even on thicker or harder labels, it includes accessories like linerless kits, peel-off kits, internal rewinder kits, and cutters, amplifying functionality to meet dynamic business demands. The printer capabilities are designed with auto-switching emulation for hassle-free deployment.

The eco-friendly Fastmark M9XPd printer boasts 100% recyclable packaging and casing, with over 90% recyclable components, minimizing its environmental impact. It's ideal for limited space and excels in print quality and versatility, making it an outstanding choice for various printing needs.

1.2 Product Specifications

Model Item	M9XPd/203dpi	M9XPd/300dpi
Resolution	8 dots/mm (203 dpi)	12 dots/mm (300 dpi)
Printing Method	Thermal Transfer & Direct Thermal	
Max. Print Speed	304.8mm (12")/second	228.6mm (9")/second
Max. Print Width	107mm (4.21")	105.7mm (4.16")
Max. Print Length	25,400mm (1000")	11,430mm (450")
Enclosure	Die-cast based print mechanism/Metal cover with large clear media view window	
Physical Dimension	248mm(W)x274mm(H)x436mm(D) 9.76"(W)x10.79"(H)x17.17"(D)	
Weight	9.1kg (20.06lbs)	
Label Roll Capacity	203.2mm(8")O.D., 1" - 3" I.D. core	
Ribbon	450m with 1" ribbon core I.D., ink coated outside or inside	
Ribbon Width	40 - 110mm(1.6" - 4.3")	
Processor	32-bit RISC CPU	
Memory	<ul style="list-style-type: none">◆ 256MB Flash memory◆ 256MB SDRAM	

Model	M9XPd/203dpi	M9XPd/300dpi
Interface	<ul style="list-style-type: none"> ◆ RS-232 ◆ USB 2.0 ◆ Internal Ethernet, 10/100 Mbps ◆ USB host, for scanner or PC keyboard ◆ GPIO (dealer option) ◆ Internal Bluetooth (dealer option) ◆ Internal Bluetooth 5.0 Mfi (factory option) ◆ Slot-in Wi-Fi 802.11 a/b/g/n/ac with Bluetooth 5.0 combo module (dealer option) 	
Power	Internal universal switching power supply <ul style="list-style-type: none"> ◆ Input: AC 100-240V, 2.0A, 50-60Hz ◆ Output: DC 24V, 3.75A, 90W 	
LED/LCD	<ul style="list-style-type: none"> ◆ 3.5" color touch LCD ◆ 1 LED (with 2 LEDs: green, red) 	
Operation Switch, Button	<ul style="list-style-type: none"> ◆ 1 power switch ◆ 6 buttons (Menu, Pause/Feed, Up, Down, Left, Right) 	
Sensors	<ul style="list-style-type: none"> ◆ Gap transmissive sensor (position adjustable) ◆ Black mark reflective sensor (position adjustable) ◆ Ribbon encoder sensor ◆ Ribbon end sensor ◆ Head open sensor 	
Real Time Clock	Standard	
Internal Fonts	<ul style="list-style-type: none"> ◆ 8 alpha-numeric bitmap fonts ◆ Monotype Imaging® true type font engine with one CG Triumvirate Bold Condensed scalable font 	
Bar code	<ul style="list-style-type: none"> ◆ 1D bar code Code 39, Code 93, Code128UCC, Code128 subsets A.B.C, Codabar, Interleave 2 of 5, EAN-8, EAN-13, EAN-128, UPC-A, UPC-E, EAN and UPC 2(5) digits add-on, MSI, PLESSEY, POSTNET, RSS-Stacked, GS1 DataBar, Code 11, China Post ◆ 2D bar code PDF-417, Micro PDF 417, Maxicode, DataMatrix, QR code, Aztec, TLC 39, RSS 	
Font & Barcode Rotation	0, 90, 180, 270 degree	
Printer Language	TSPL-EZD (EPL, ZPL, ZPL II, DPL)	
Media Type	Continuous, die-cut, black mark, fan-fold, notched (outside wound)	
Media Width	20mm - 120mm (0.8" - 4.7")	
Media Thickness	0.06mm - 0.28mm (2.36mil - 11mil)	
Media Core Diameter	25.4 - 76.2mm (1" - 3")	

Label Length	5 - 25,400mm(0.2" - 1000")	5 - 11,430mm(0.2" - 450")
Environment Condition	<ul style="list-style-type: none"> ◆ Operation: 0°C to 40°C (32°F to 104°F), 25% - 85% non-condensing ◆ Storage: -40°C to 60°C (-40°F to 140°F), 10% - 90% non-condensing 	
Factory Option	Internal Bluetooth 5.0 MFi	
Dealer Option	<ul style="list-style-type: none"> ◆ Peel-off kit ◆ Regular guillotine cutter (full cut) ◆ 5" O.D. internal rewinding kit ◆ GPIO ◆ Linerless tear-off kit ◆ Linerless cutter kit ◆ Slot-in Wi-Fi 802.11 a/b/g/n/ac with Bluetooth 5.0 combo upgrade kit (for device without slot-in housing)* ◆ Internal Bluetooth 5.0 module** 	
User option	<ul style="list-style-type: none"> ◆ Slot-in Wi-Fi 802.11 a/b/g/n/ac with Bluetooth 5.0 combo module (for device with slot-in housing) ◆ KP-200 Plus keyboard display unit ◆ Universal cutter tray 	

2. Operations Overview

2.1 Unpacking and Inspection

This printer has been specially packaged to withstand damage during shipping. Please carefully inspect the packaging and printer upon receipt. Please retain the packaging materials in case you need to reship the printer.

Unpacking the printer, the following items are included in the carton.

- 1 Printer unit
- 1 Quick start guide
- 1 Power cord
- 1 USB interface cable

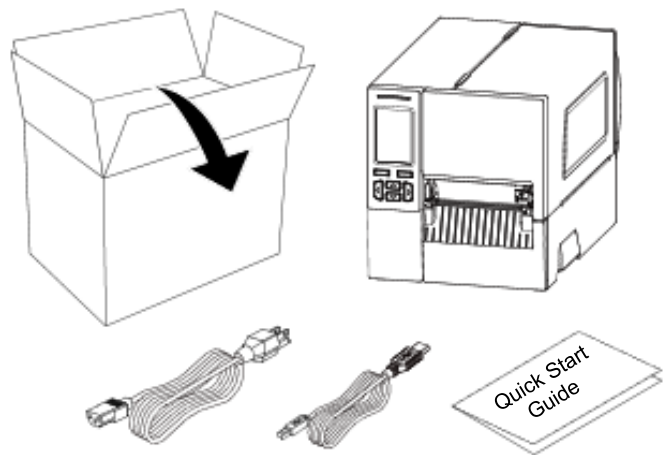

Note: If any parts are missing, please contact the Customer Service Department of your purchased reseller or distributor.

2.2 Printer Overview

2.2.1 Front View

M9XPd Series



1. LED indicator
2. LCD display
3. Front panel buttons
4. Media view window
5. Paper exit chute
6. Printer cover handle

2.2.2 Interior view M9XPd Series

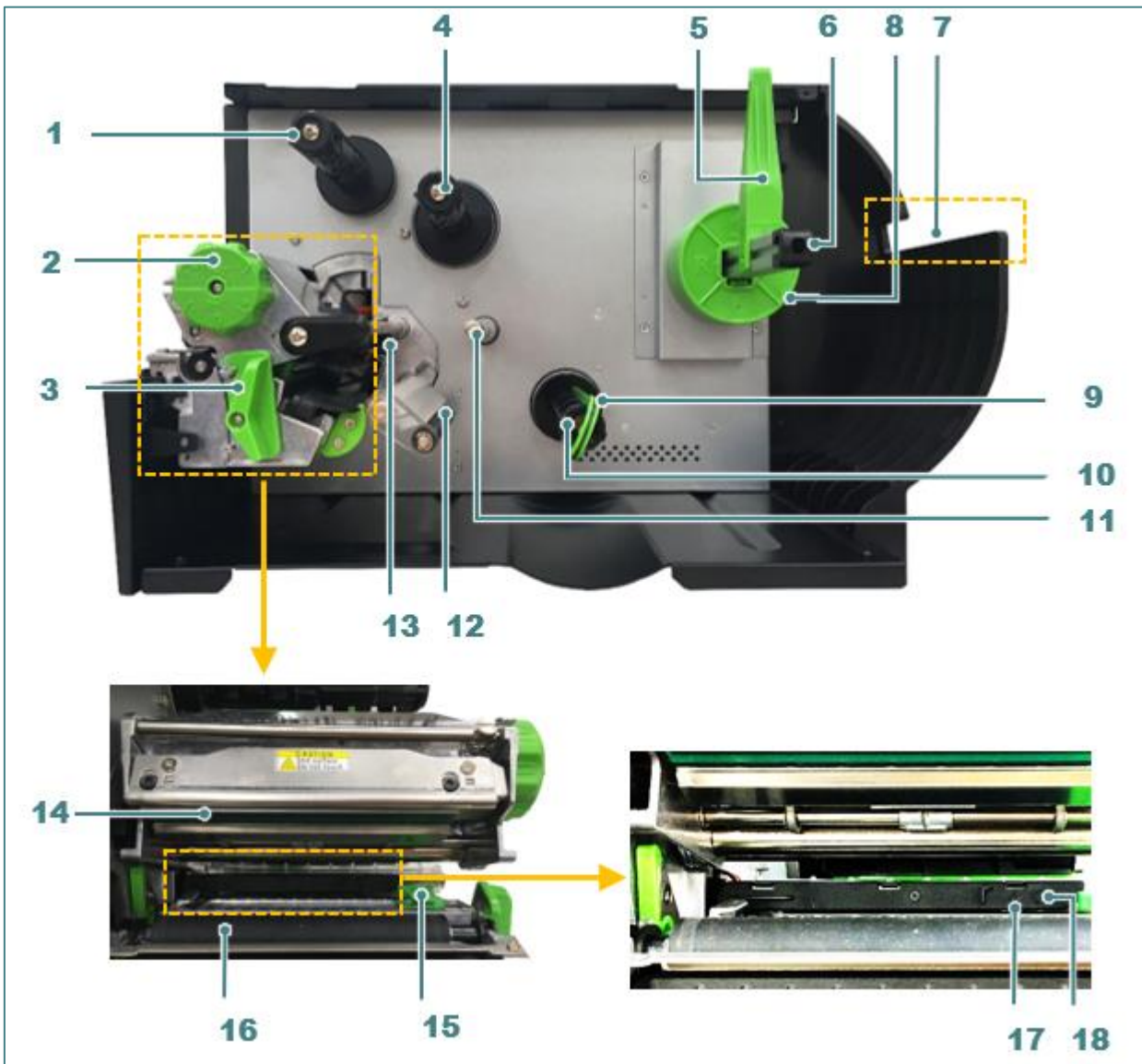

- | | |
|--|--|
| 1. Ribbon rewind spindle | 10. Liner rewind spindle (Optional kit of Peel-off module ass'y) |
| 2. Print head pressure adjustment knob | 11. Media guide bar (Optional kit of Peel-off module ass'y) |
| 3. Print head release lever | 12. Damper |
| 4. Ribbon supply spindle | 13. Ribbon end sensor |
| 5. Label roll guard | 14. Printhead |
| 6. Label supply spindle | 15. Front label guide |
| 7. External label entrance chute | 16. Platen roller |
| 8. 3" core adapters | 17. Black mark sensor (shown as ↓) |
| 9. Liner securing clip (Optional kit of Peel-off module ass'y) | 18. Gap sensor (shown as ▽) |

2.2.3 Rear View

M9XPd Series

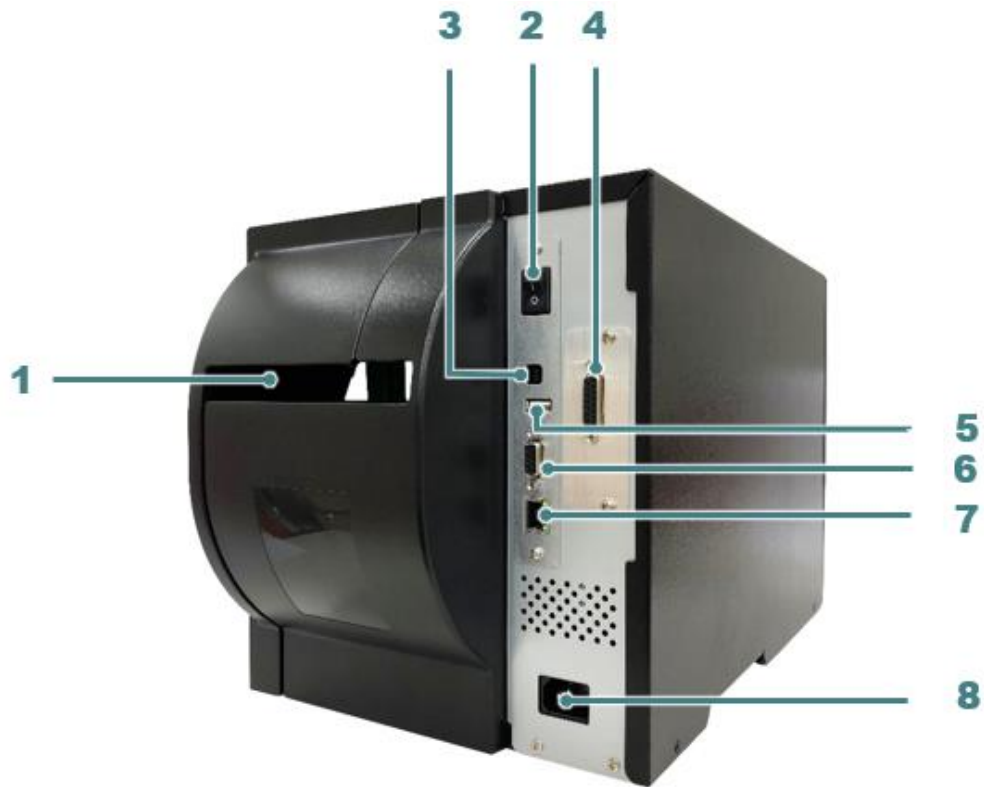

1. External label entrance chute
2. Power switch
3. USB interface (High speed mode)
4. Slot-in Wi-Fi or GPIO interface (Option)
5. USB host
6. RS-232C interface
7. Ethernet interface
8. Power cord socket



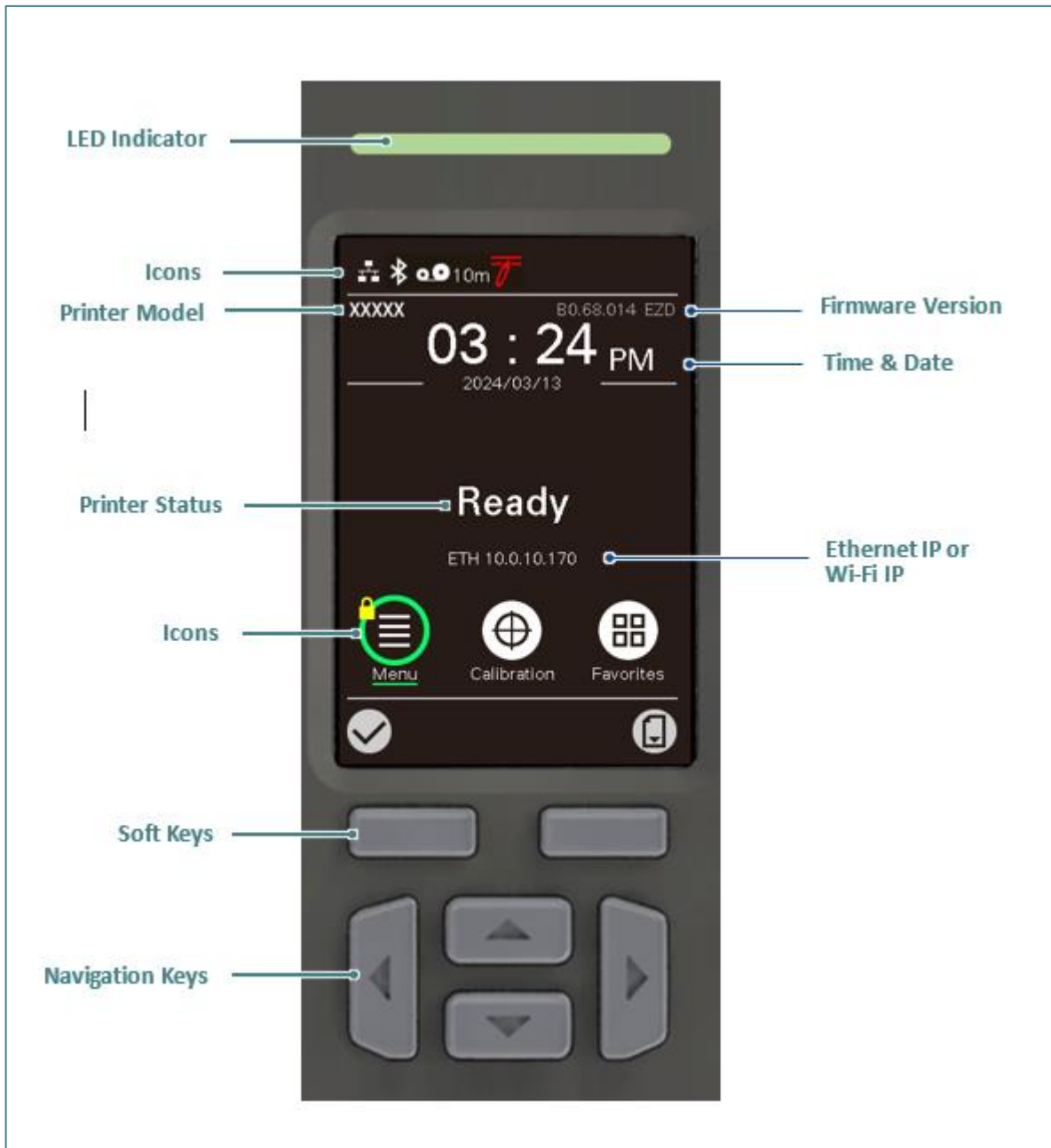

Note:

The interface picture here is for reference only. Please refer to the product specification for the interface availability.









2.3 Operator Control





2.3.1 LED Indication and Keys

LED	Status	Indication	
	Green	Solid	This illuminates when the power is on and the device is ready to use.
		Flash	This illuminates when the system is downloading data from PC to memory or the printer is paused.
	Amber	This illuminates when the system is clearing data from printer.	
	Red	Solid	This illuminates with printer head open and cutter error.
		Flash	This illuminates with a printing error, such as head open, paper empty, paper jam, or memory error etc.
Keys		Function	
Select keys 		The labels on the footer of the UI will explain the function for left and right soft key. Check the labels on the footer of the UI screen. The meaning of the select keys will vary.	
Navigational keys 		Used to select icons, menu selection, and navigation in the UI.	

2.3.2 Main page Icons

Indicated icon	Indication
	Wi-Fi device is ready (option)
	Ethernet is connected
	Bluetooth device is ready (option)
	Media capacity (%)
	Ribbon capacity (m)
	TPH cleaning
	Security lock
Icon button	Function
	Enter the menu
	Calibrate the media sensor

Main page Icons cont.

	Enter the "Favorites" option (please refer to section 7.9)
	Enter cursor (be marked in green) located option
	Feed button (advance one label)

2.3.3 Touch Screen Operation

Tap on an item to open/use it.

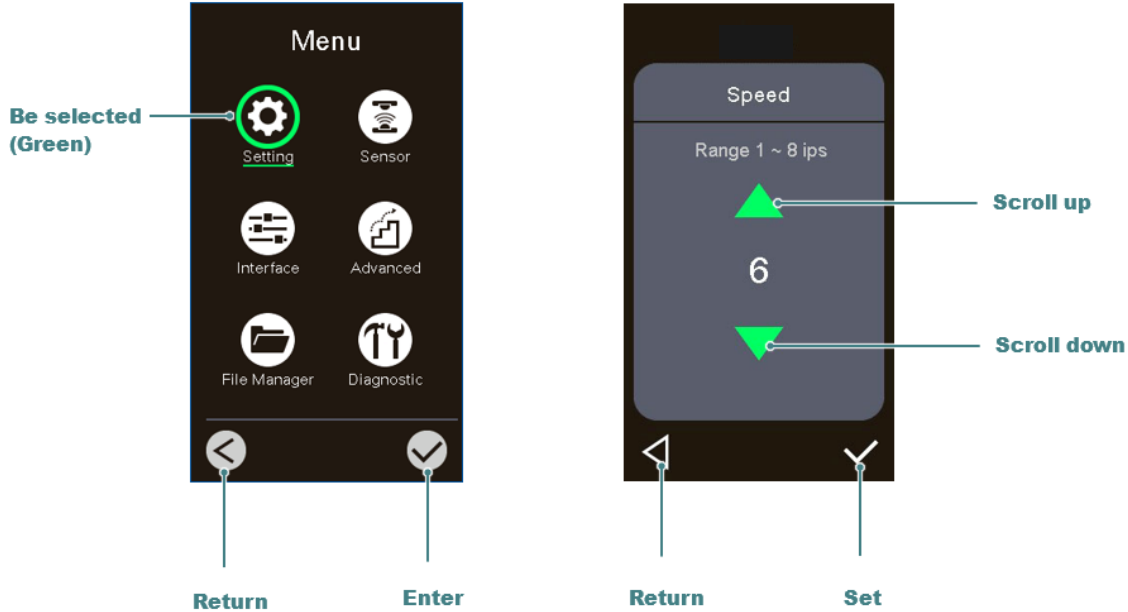

Be selected (Green)

Return **Enter**

Scroll up



Scroll down

Return **Set**

2.3.4 Power-On Utilities

M9XPd Series have power-on utilities for the user to set sensor calibration, self-test, factory default functions. Please refer to the template below to setup the settings.

Follow the steps below for different power-on utilities.

1. Turn off the printer power switch.
2. Hold on the right side of the select key ( ) then turn on the power switch.
3. Release the button when LCD monitor indicates with different functions.
4. The printer will setup the functions showing on the LCD monitor accordingly.

The sequences of the settings:

Power on utilities	The LED color will be changed as following pattern:						
 LED color Functions (showing on LCD monitor)	Amber	Red (5 blinks)	Amber (5 blinks)	Green (5 blinks)	Green/Amber (5 blinks)	Red/Amber (5 blinks)	Solid green
1. Sensor Calibration (Gap / black mark sensor)		Release					
2. Self-test and enter dump mode			Release				
3. Factory Default				Release			
4. <u>Bline Calibration</u>					Release		
5. Gap Calibration						Release	
6. <u>READY (Skip AUTO.BAS)</u>							Release

2.4 Web User Interface

Web User Interface enables users to control and manage the printer using a remote device over network.

2.4.1 Opening the Web User Interface

Follow the steps below to open the web user interface for the printer:

1. Make sure the printer is connected to the network and obtain the IP address.
Note: If the printer is connected to the network, you can see the IP address on the LCD panel. For how to connect to the network, ask your IT staff or refer to the interface section.
2. Open the browser on your computer.
3. Enter the printer’s IP address inside the browser’s address bar and then press “Enter”.

- ❖ Due to regional regulations, users logging in for the first time in specific areas will be prompted to set a new user name and user password. When you log in for the first time, the printer prompts you to set a new user/administrator name and user/administrator password.
- ❖ Enter the user and administrator names and passwords. Then, enter "admin" in the current administrator password field and press the [Set] key to set. (User name & password: view the printer settings; Administrator name & password: set the printer settings).

- ❖ The password setting rules are as follows: the length is limited to 8 to 15 characters, it must contain at least one uppercase and lowercase letter and a number. The content can be English letters, numbers, or symbols, but does not support double-byte characters.
 - ❖ To consider security, the printer will restart if you enter an incorrect password 5 times.
4. When the following screen (Remote Panel) appears, you can start using the web user interface to manage the printer.

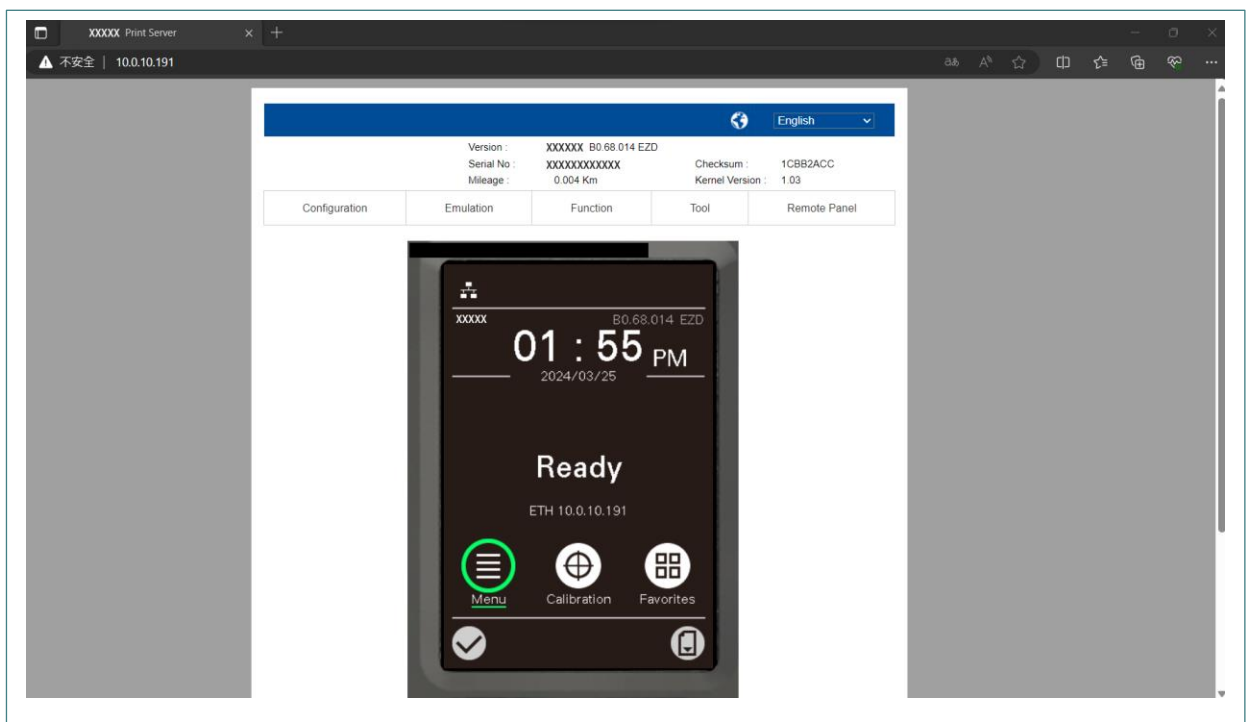

2.4.2 Introduction to Web User Interface



The screenshot displays the printer's web user interface. At the top, there is a blue header bar with a language dropdown menu set to 'English'. Below this, a white box contains printer information: Version: XXXXX B0.68.014 E2D, Serial No: XXXXXXXXXXXXX, Mileage: 0.004 Km, Checksum: 1CBB2ACC, and Kernel Version: 1.03. A horizontal menu bar below the information box includes 'Configuration', 'Emulation', 'Function', 'Tool', and 'Remote Panel'. The central part of the interface is a visualized control interface for the LCD screen, showing a digital clock at 02:33 PM on 2024/03/25, the word 'Ready', and the IP address ETH 10.0.10.191. Below the text are three icons: 'Menu' (a green circle with a white list icon), 'Calibration' (a white circle with a crosshair), and 'Favorites' (a white circle with a grid icon). At the bottom of the control interface is a virtual keypad with a green 'OK' button and four directional arrow buttons.

Language switching

Printer Model, Firmware Version, Serial Number etc.

Function menu bar (see the following section for details)

Visualized Control Interface
The content you see here is exactly the same as what is displayed on the LCD screen of the actual printer, you can operate/setup the printer remotely directly from here.

Note:

- ♦ 3.5" touchscreen LCD panel allows mouse click operation directly on this LCD screen.
- ♦ 2.3" LCD panel can be operated by clicking the buttons below (mouse over the buttons and the screen will appear green).

For how to use the buttons and setting options on the control panel, you can refer to LCD Operator Control section.

2.4.3 Function menu

■ Configuration

Item		Description
Print	Common	Configures the printer using the TSPL command set. Refer to Error! Reference source not found. section for more information.
	Adjust	Adjusts the print and stop location. Refer to Error! Reference source not found. section for more information.
	Media	Configures the parameters that relate to the media type and sets the media sensor.
	Calibration	Configures the parameters that affect the media calibration.
RS232		Configures the settings for RS-232.
Bluetooth		Configures the settings for Bluetooth.
Ethernet		Configures the settings for Ethernet.
802.1X		Sets the 802.1X authentication.
Wi-Fi		Configures the settings for Wi-Fi.
Raw Port Filter		Configures the settings for RAW port filter.
RTC Setup		Sets the date and time for the printer.

■ Emulation

Item	Description
Z	Configures settings for the ZPL emulation
D	Configures settings for the DPL emulation

■ Function

Item	Description
SOTI settings	Sets the MQTT server and manages the CA certificate files.
TPH Care	Monitors the printhead's health status.
Email	Sets the SMTP server.
SNTP	Sets the SNTP server.
SNMP	Configures the SNMP (Simple Network Management Protocol) for the printer.
Web Password	Sets the user/administrator name and its corresponding password.
Log	Records the printer's activities.
Function	Provides quick access to the following functions: <ul style="list-style-type: none"> • Reset Printer • Configuration Page • Sensor Calibration • Factory Default • Ignore AUTO.BAS • Preferred Wi-Fi / Preferred Ethernet • Send File to Printer

■ Tool

Item	Description
File Manager	Manages the files saved in the built-in memory.
Communication Tool	Sends command sets or instructions to the printer.
Update Firmware	Updates the printer's firmware.
Clear Browsing Record	Clears the browsing record.
Classic Webpage	Switches to the classic user interface.

■ Remote Panel

This option returns you to the Visualization Control Interface page.





3. Setup

3.1 Setting up the Printer





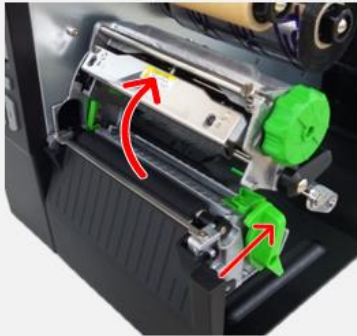

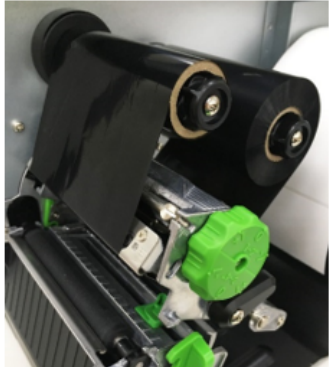
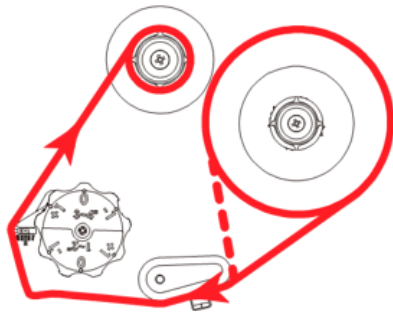
1. Place the printer on a flat surface.
2. Make sure the printer is power off.
3. Connect the printer to the computer with the provided USB cable.
4. Plug in the power cord on the rear side of the printer.
5. Fully insert the power cord plug into the power outlet socket.

Note: Please switch OFF the printer before plugging in the power cord to printer power jack.

3.2 Loading the Ribbon

	<p>1. Open the media cover.</p>		<p>2. Slide the ribbon onto the ribbon supply spindle until it is flush with the flange. 3. Install the paper core onto the ribbon rewind spindle in the same way.</p>
	<p>4. Release the lever to open the printhead.</p>		<p>5. Thread the ribbon through the open space between printhead and platen roller. Then pull the ribbon onto the paper core.</p>
	<p>6. Wrap the ribbon onto the rewind spindle. Keep the ribbon flat and without wrinkles. 7. Wind the ribbon clockwise about 3~5 turns onto the ribbon take-up spindle until it is smooth and properly stretched tight.</p>	<p>Ribbon Loading Path</p>  <p> —— Ink coated outside. - - - Ink coated inside </p>	

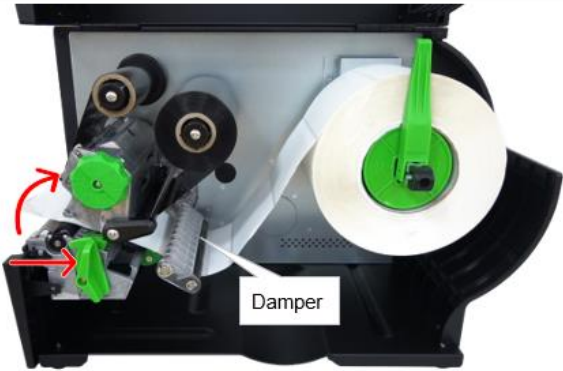
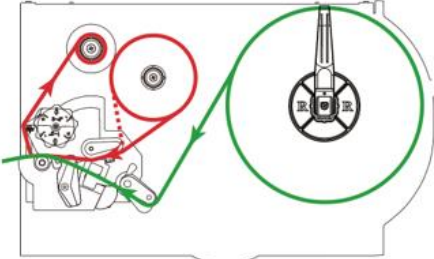
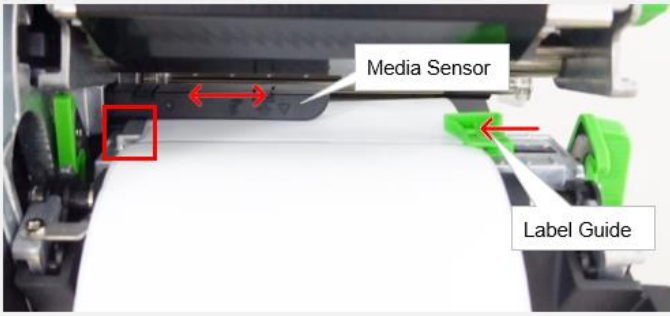
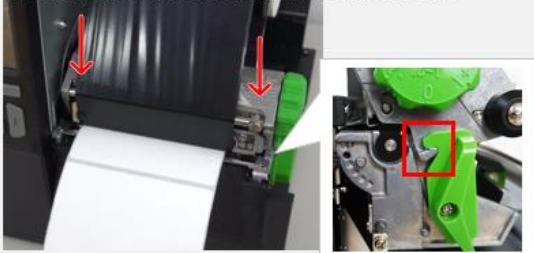

3.3 Loading the Media

	<p>1. Open the media cover.</p>		<p>2. Slide the label roll guard to the end of the spindle then flip it down.</p>
	<p>3. Place media roll on the label supply spindle (with 3" core adapters) and push it to the end of the spindle.</p>		<p>4. Flip the label roll guard up and push it to fit the width of label roll.</p>
	<p>5. Release the lever to open the printhead. Thread the label through the damper, media sensor, and label guide.</p> 		
	<p>6. Adjust the position of the media sensor. 7. Adjust the label guide to fix the media position. 8. Close the printhead ensuring that the printhead is correctly locked by the printhead release lever.</p> 		
<p>9. Using the front display panel to perform a calibration for the media in use. For touch LCD, press  icon to calibrate the sensor. For 2.3" LCD, refer to Sensor section for more information.</p>			

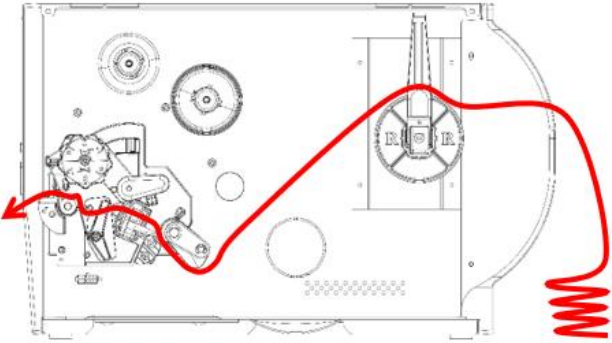
3.4 Loading the Fanfold/External Media

	<ol style="list-style-type: none"> 1. Open the media cover. 2. Insert the fanfold media through the rear external label entrance chute.  <ol style="list-style-type: none"> 3. Refer Loading the Media section to load the media.
---	--

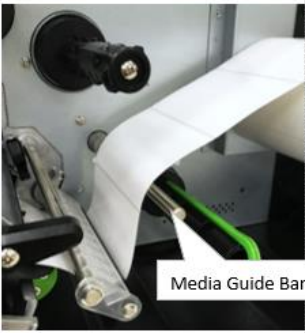
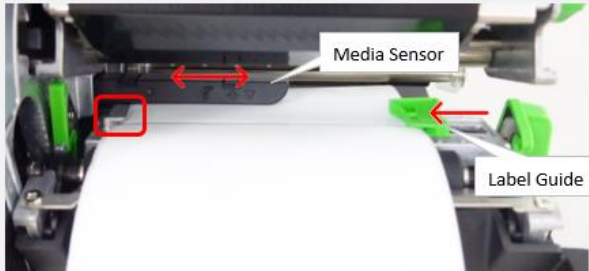
3.5 Loading the Media in Peel-off Mode (Optional)

	<ol style="list-style-type: none"> 1. Open the media cover and load the media. 2. Release the lever to open the printhead. 	 <p>Media Guide Bar</p> <ol style="list-style-type: none"> 3. Install the label as indicated. (Pass the label over the top of guide bar and under the damper, through media sensor, and label guide.)
 <p>Media Sensor</p> <p>Label Guide</p>		<ol style="list-style-type: none"> 4. Adjust the position of the media sensor and the label guide to fix the media position. 5. Close the printhead. Using the front display panel to perform a calibration for the media first. For touch LCD, press  icon to calibrate the sensor. For 2.3" LCD, refer to Sensor section for more information. <p>Note: Calibrate the sensor before loading the media in the peel-off mode to avoid the paper jam.</p> <ol style="list-style-type: none"> 6. Set the print mode to the Peeler Mode. Refer to Setting section. (Setting > Print Mode) <p>Note: The Print Mode can also be set through the Driver or the Printer Utility.</p>

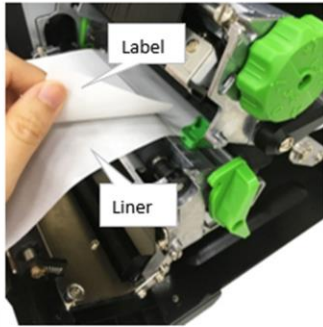

7. Release the lever to open the printhead after calibrating. Release peel-off module lever.
8. Pull the label out about 650mm and peel off a few labels, leaving the liner.



9. Feed the leading edge of liner through the peel-off module slot as indicated.



10. Pull out the securing clip (green). Wind the liner onto the spindle until the liner stretched properly.
11. Insert the securing clip to secure the liner.



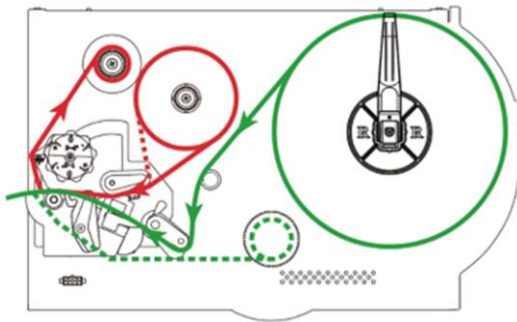

Note:
The liner can also be secured onto the rewind spindle with the paper core.





12. Close the peel-off module and the printhead.
13. Press the FEED button to test the operation of the peeler.

— Label with liner
- - - Liner

3.6 Loading the Media in Cutter Mode (Optional)

	<ol style="list-style-type: none"> 1. Open the media cover, the printhead, and the cutter module. 2. Refer to Loading the Media section to load the media and make it undergo through the cutter paper entrance. 		<ol style="list-style-type: none"> 3. Close the printhead and the cutter module.
<ol style="list-style-type: none"> 4. Using the front display panel to perform a calibration for the media. For touch LCD, press  icon to calibrate the sensor. For 2.3" LCD, refer to Sensor section for more information. 5. Set the print mode to the Cutter Mode. Refer to Setting section. (Setting > Print Mode) <p>Note: The Print Mode can also be set through the Driver or the Printer Utility.</p> <ol style="list-style-type: none"> 6. Press the FEED button to test the operation of the cutter. 			

3.7 Loading the Linerless Media (Optional)

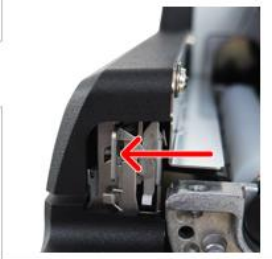
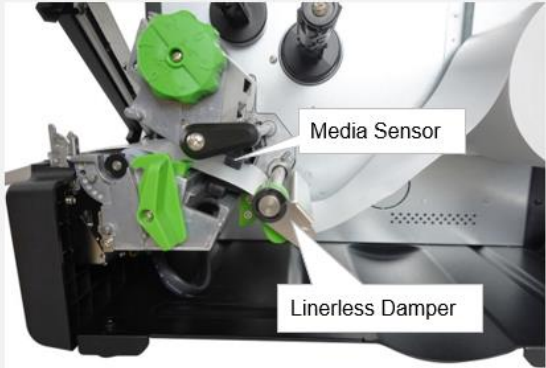
	<ol style="list-style-type: none"> 1. Open the media cover and the printhead. 		<ol style="list-style-type: none"> 2. Open the upper bar for the linerless cutter (or tear) module gate. 
	<ol style="list-style-type: none"> 3. Refer to Loading the Media section to thread the media under the damper, through the media sensor and under the printhead. Keep feeding the media until the media extends out of the front side of the linerless cutter (or tear) module. 		



4. Align the media with the media guide ensuring that the media is threaded under the guide.



5. Adjust the media guide ensuring that the location of the guide fits with the media's width.

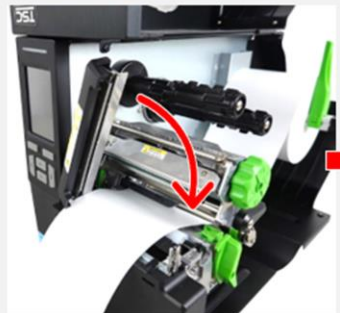

6. Close the upper bar for the linerless cutter (or tear) gate.
 7. Close the printhead ensuring that the printhead is correctly locked by the printhead release lever.
 8. Close the media cover.
 9. Refer to [Configuring the Printer and Setting Options for the Linerless Media](#) section to setting the linerless printer.

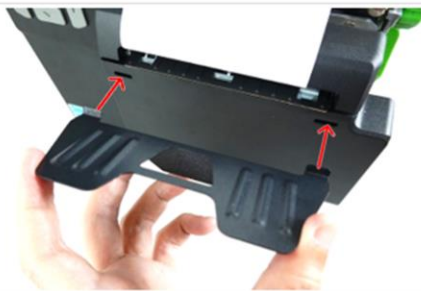

10. (For cutter module only) Insert the ribs on the label tray into its corresponding opening on the front panel of the cutter module.

■ The images below demonstrate the two printers shipped with cutter module and tear module respectively.

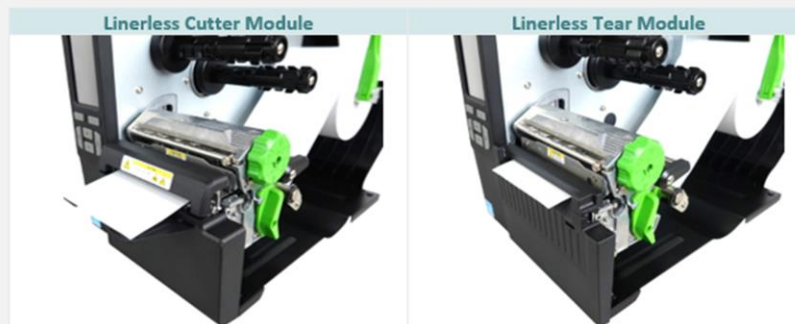

Note:
 The loading media for linerless tear and linerless cutter modules are in the same way, this section mainly demonstrates the Linerless Cutter Module as an example.

4. Adjustment Knob

4.1 Printhead Pressure and Position Adjustment

The printhead pressure adjustment knob has 6 levels of adjustment for 1" to 2" and 3" to 4" width media. Because the printer's paper alignment is to the left side of mechanism, different media widths require the different pressure to print the label correctly. Users can try which level can meet their expectation.

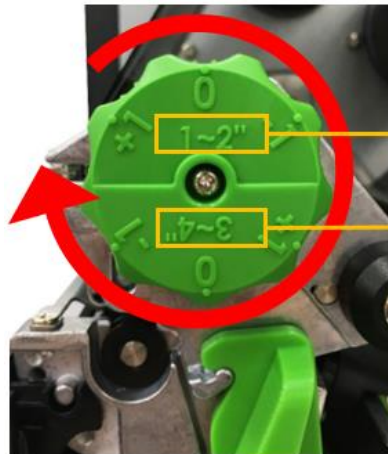

Print Head Pressure Adjustment range from 1~2" media width

Printhead Pressure Adjustment range from 3" to 4" media width

- 0 means regular media thickness (0.005" to 0.006") pressure setting.
- -1 means lower pressure for thin paper media
- +1 means higher pressure for thick media

4.2 Ribbon Tension Adjustment Module

The ribbon tension adjustment screw has 5 positions for adjustment. Different width of ribbon may need to adjust the tension adjustment knob to avoid the ribbon wrinkle and get the best print quality. Refer to [Error! Reference source not found.](#) section for how to adjust.

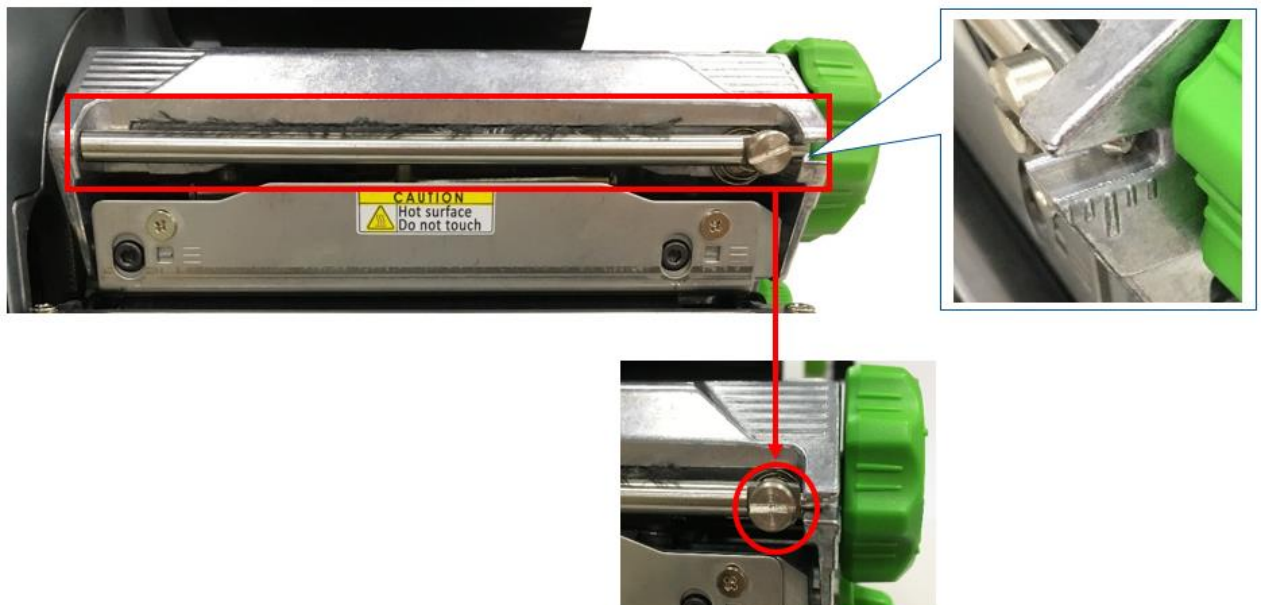

4.3 Mechanism Fine Adjustment to Avoid Ribbon Wrinkles

This printer has been fully tested before delivery. There should be no ribbon wrinkle present on the media for general-purpose printing applications. Ribbon wrinkle is related to the media width, thickness, printhead pressure balance, ribbon film characteristics, print darkness setting...etc. In case ribbon wrinkle occurs, please follow the instructions below to adjust the printer parts.

Ribbon Tension Adjustment Knob has 5 indexes for adjustment. Use flat screwdriver to change the ribbon tension.

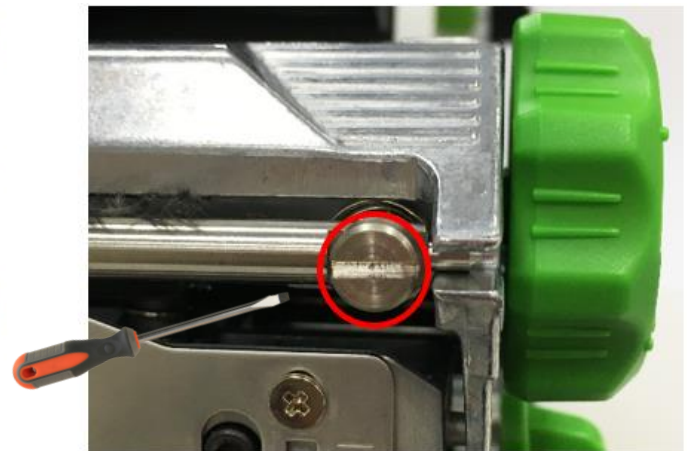

When wrinkle occurs from label lower right to upper left direction.



- Make sure the Printhead Pressure Adjustment Knob (green) is in correct position for the current media width. (1 to 2" or 3 to 4")
- Turn the screw clockwise per level and print to see if the wrinkle has gone.
- If the ribbon tension adjustment knob has positioned on the level of innermost side but the ribbon wrinkle cannot be removed, please switch the printhead pressure (green) at 1 level and print the label again to check if the wrinkle is gone.
- If the wrinkle can't be avoided, please contact the Customer Service Department of your purchased reseller or distributor for service.

When wrinkle occurs from label lower left to upper right direction.



- Make sure the Printhead Pressure Adjustment Knob (green) is in correct position for the current media width. (1" to 2" or 3" to 4")
- Turn the screw counterclockwise per level and print to see if the wrinkle has gone.
- If the ribbon tension adjustment knob has positioned on the level of outermost side but the ribbon wrinkle cannot be removed, please switch the printhead pressure (green) at 1 level and print the label again to check if the wrinkle is gone.
- If the wrinkle can't be avoided, please contact the Customer Service Department of your purchased reseller or distributor for service.

5. Diagnostic Tool

AMTDS's Diagnostic Utility is an integrated tool incorporating features that enable you to explore a printer's settings/status; change a printer's settings; download graphics, fonts, and firmware; create a printer bitmap font; and send additional commands to a printer. With the aid of this powerful tool, you can review printer status and settings in an instant, which makes it much easier to troubleshoot problems and other issues.

5.1 Start the Diagnostic Tool

- Double click on the Diagnostic tool icon  `DiagTool.exe` to start the software.
- There are four features (Printer Configuration, File Manager, Bitmap Font Manager, Command Tool) included in the Diagnostic utility.

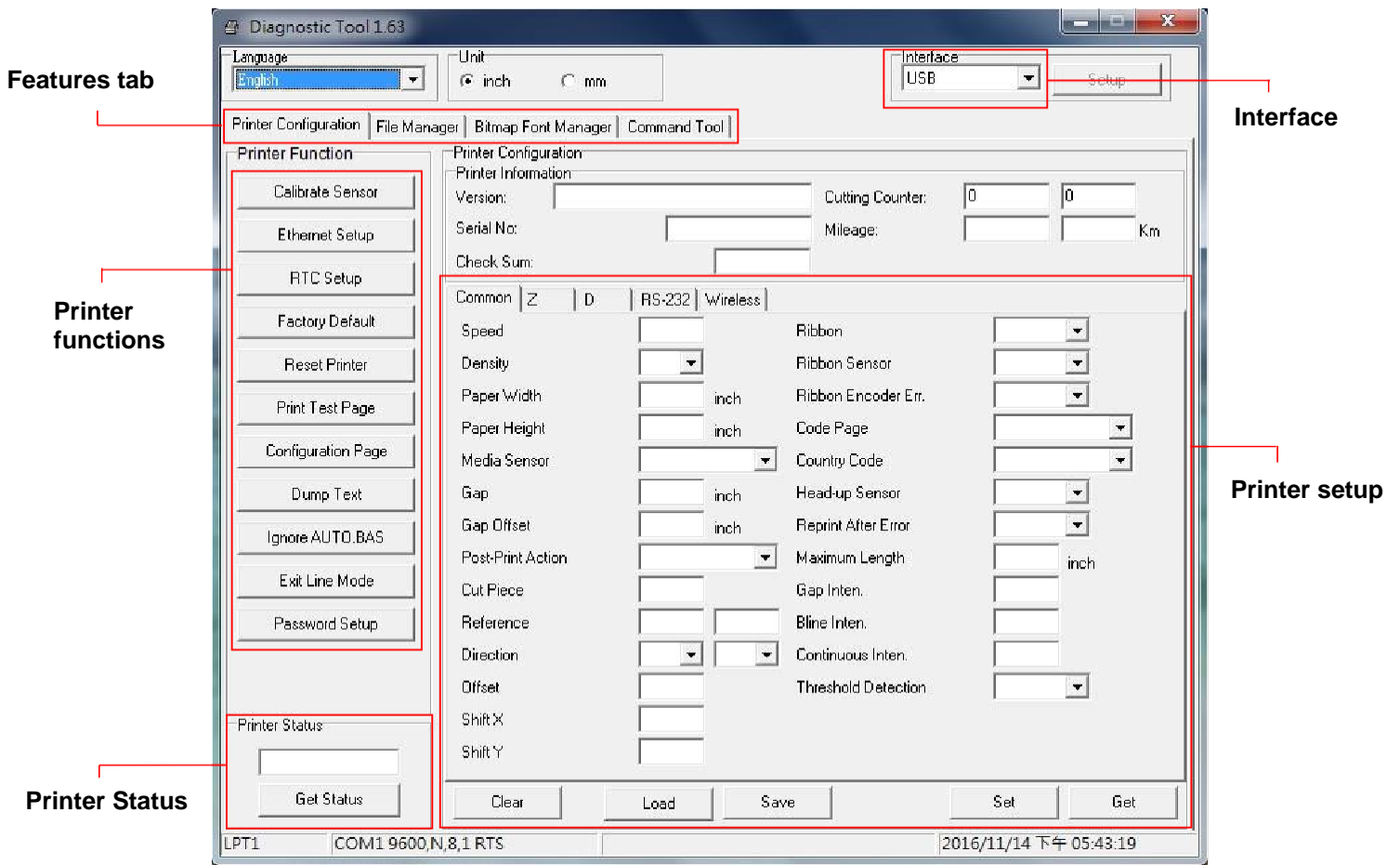

5.2 Printer Function

1. Connect the printer and computer with a cable.
2. Select the PC interface connected to the bar code printer.

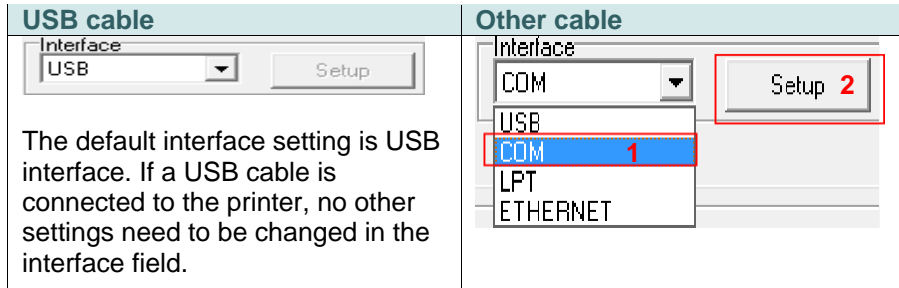

3. Click the “Printer Configuration” tab to adjust settings.
4. The detail functions in the Printer Function Group are listed as below.

Printer Function	Function	Description
Calibrate Sensor	Calibrate Sensor	Calibrate the sensor specified in the Printer Setup group media sensor field
Ethernet Setup	Ethernet Setup	Setup the IP address, subnet mask, gateway for the onboard Ethernet
RTC Setup	RTC Setup	Synchronize printer Real Time Clock with PC
Factory Default	Factory Default	Initialize the printer and restore the settings to factory default.
Reset Printer	Reset Printer	Reboot printer
Print Test Page	Print Test Page	Print a test page
Configuration Page	Configuration Page	Print printer configuration
Dump Text	Dump Text	To activate the printer dump mode.
Ignore AUTO.BAS	Ignore AUTO.BAS	Ignore the downloaded AUTO.BAS program
Exit Line Mode	Exit Line Mode	Exit line mode.
Password Setup	Password Setup	Set the password to protect the settings

5.3 Setting Ethernet by Diagnostic Tool

The Diagnostic Utility is enclosed in the CD disk \ Utilities directory. Users can use Diagnostic Tool to setup the Ethernet by RS-232, USB and Ethernet interfaces. The following contents will instruct users how to configure the Ethernet by these three interfaces.

1. Using USB interface to setup Ethernet interface

- a) Connect the printer and computer with a USB cable.
- b) Turn on the printer power switch.
- c) Start the Diagnostic Utility by double clicking on the  `DiagTool.exe` icon.
- d) The Diagnostic Utility default interface setting is USB interface. If USB interface is connected to the printer, no other settings need to be changed in the interface field.

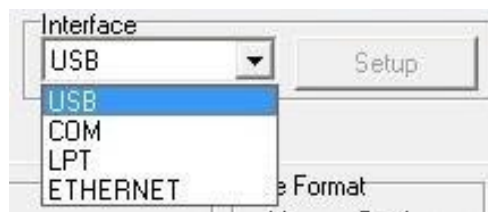

- e) Click on the “Ethernet Setup” button from “Printer Function” group in Printer Configuration tab to setup the IP address, subnet mask and gateway for the onboard Ethernet.

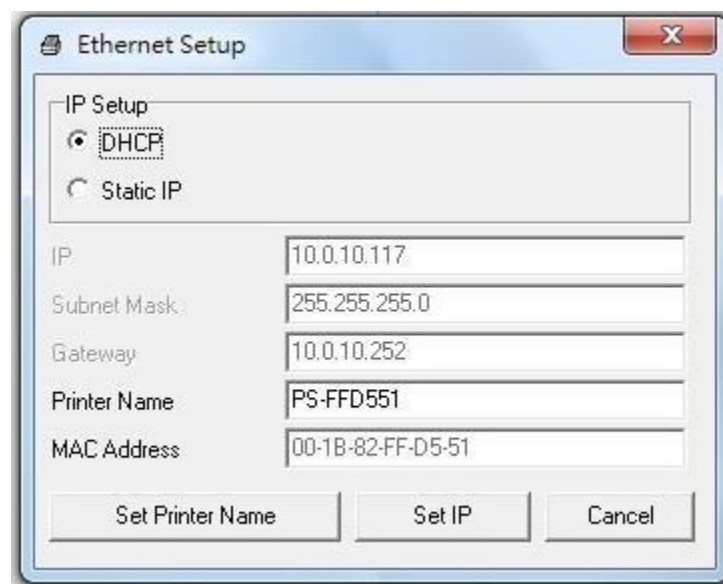

2. Using RS-232 interface to setup Ethernet interface

- a) Connect the computer and the printer with a RS-232 cable.
- b) Turn on the printer power.
- c) Start the Diagnostic Utility by double clicking on the  `DiagTool.exe` icon.
- d) Select “COM” as interface then click on the “Setup” button to setup the serial port baud rate, parity check, data bits, stop bit and flow control parameters.

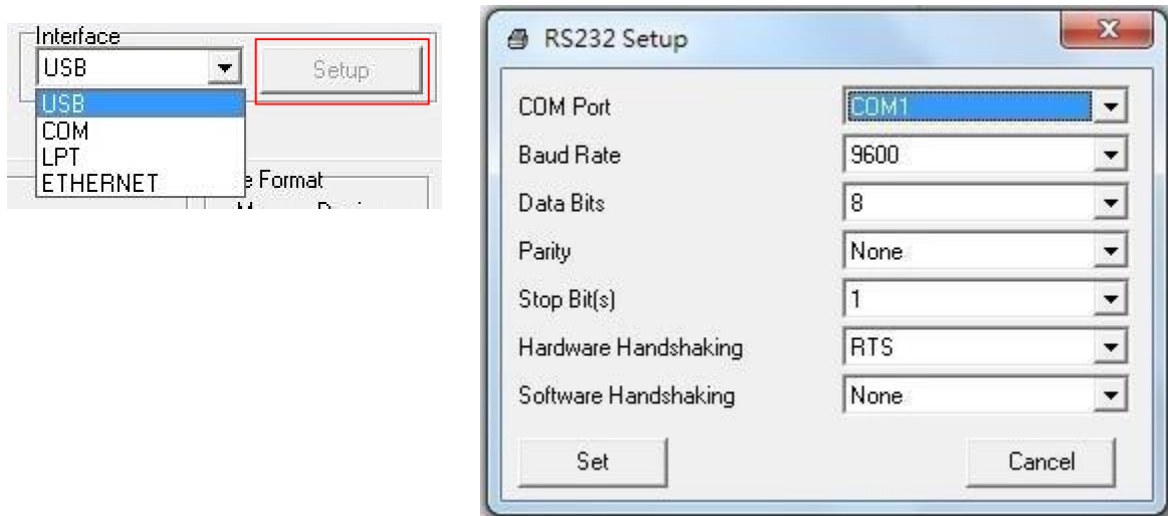

- e) Click on the “Ethernet Setup” button under Printer Function on the Printer Configuration tab to setup the IP address, subnet mask and the gateway for the onboard Ethernet.

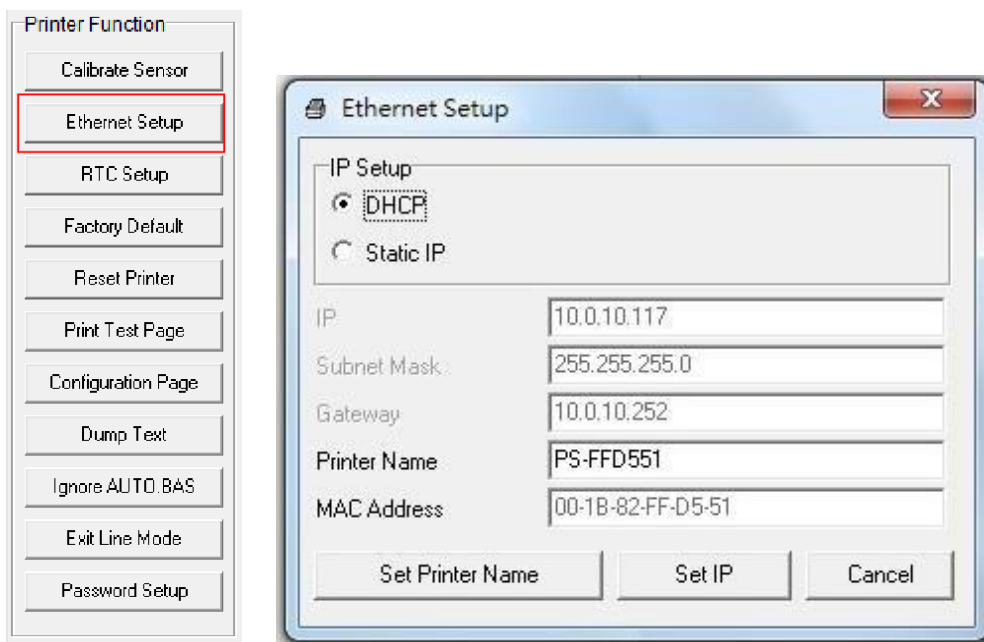

3. Using Ethernet interface to setup Ethernet interface

- a) Connect the computer and the printer to the LAN.
- b) Turn on the printer power.
- c) Start the Diagnostic Utility by double clicking on the  **DiagTool.exe** icon.
- d) Select “Ethernet” as the interface then click on the “Setup” button to setup the IP address, subnet mask and gateway for the onboard Ethernet.

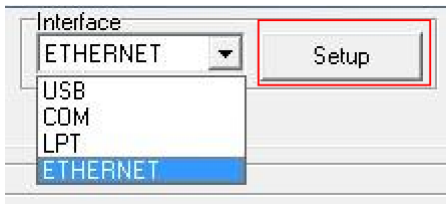

- e) Click the “Discover Device” button to explore the printers that exist on the network.
- f) Select the printer on the left side of listed printers, the corresponding IP address will be shown in the “IP address/Printer Name” field.
- g) Click “Change IP Address” to configure the IP address obtained by DHCP or static.

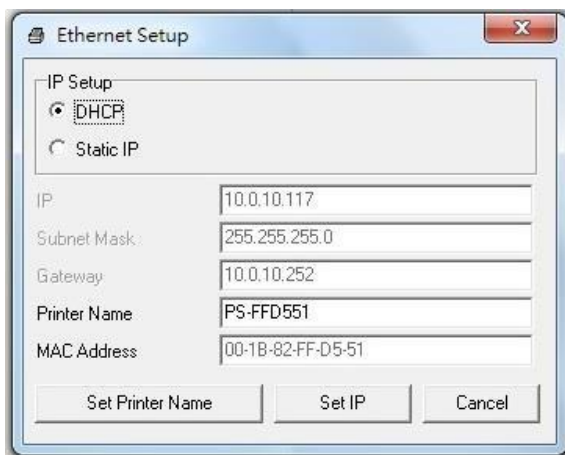

The default IP address is obtained by DHCP. To change the setting to static IP address, click the “Static IP” radio button then enter the IP address, subnet mask and gateway. Click “Set IP” for the settings to take effect.

Users can also change the “Printer Name” field to another user preferred name. Click “Set Printer Name” for this to take effect.

Note: After clicking the “Set Printer Name” or “Set IP” button, the printer will reset to invoke the settings.

- h) Click “Exit” button to exit the Ethernet interface setup and go back to Diagnostic Tools’ main screen.

“Factory Default” button

This function will reset the IP, subnet mask, gateway parameters obtained by DHCP and reset the printer name.

“Web setup” button

An exception to using the Diagnostic Utility to setup the printer is you can also explore and configure the printer settings and status or update the firmware with a web browser. This feature provides a user-friendly setup interface and the capability to manage the printer remotely over a network.

6.0 LCD Menu Function

6.1 Enter the Menu

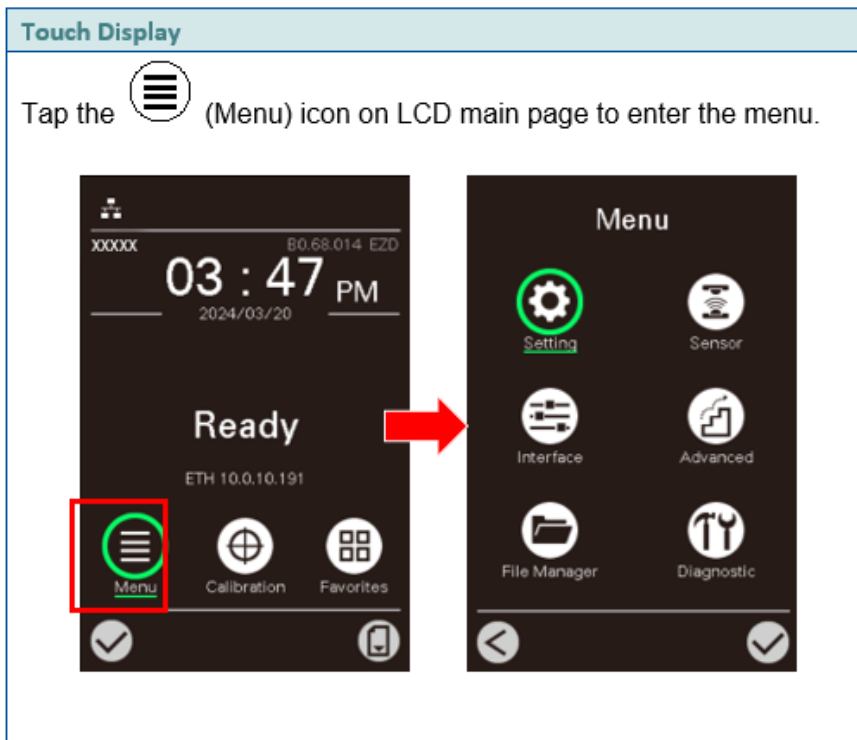

6.2 Menu Overview

There are 6 categories for the menu. You can easily change the settings of the printer without connecting to the computer. Please refer to the following sections for more details.



This "Setting" category can set up the printer settings for TSPL & ZPL2.



This "Sensor" option is used to calibrate the selected media sensor. We recommend calibrating the sensor before printing when changing the media.

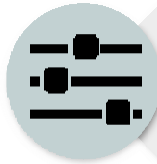

This "Interface" option is used to set the printer interface settings.



This "Advanced" option is used to set the printer LCD settings, initialization, cutter type, media low warning setting %...etc.



This "File Manager" option is used to check/manage the printers' available memory.



This "Diagnostic" option is used to query the printer to troubleshoot problems and other issues.

6.3 Setting

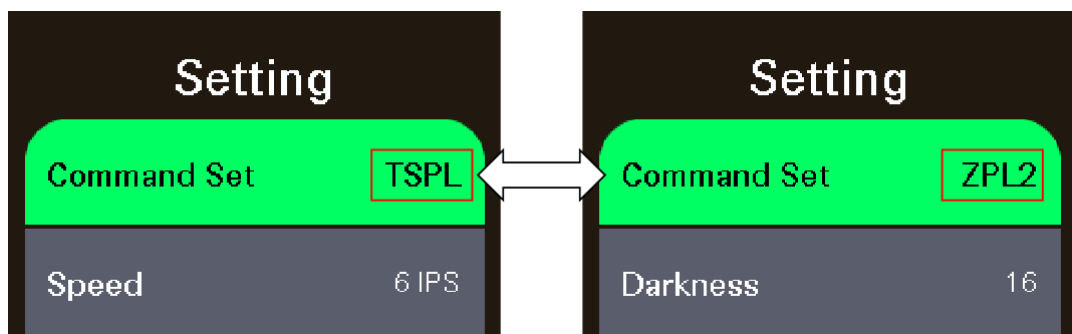

Tap the "Command Set" item on LCD to switch between TSPL and ZPL2. Or select the "Command Set" item by navigational key and press right soft key to switch between TSPL and ZPL2.

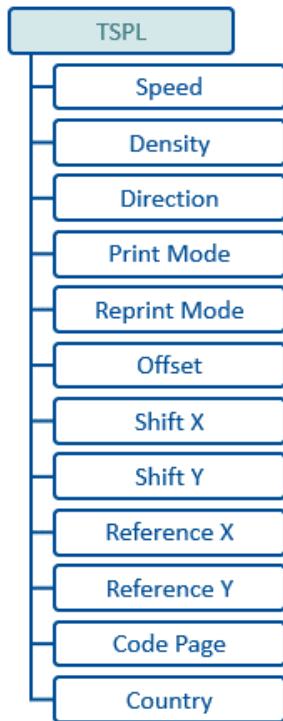

1. TSPL

The following illustration and table describe the TSPL command set.



Item	Description	Default
Speed	Set the print speed. Setting range: 1 to 10 for 203dpi; 1 to 7 for 300dpi.	203 dpi: 5 300 dpi: 3
Density	Set printing darkness. Setting range: 0 to 15, and the step is 1.	8
Direction	Set the printout direction. Setting Value: 0 and 1. (Feed direction ↓) Direction 0:  Direction 1: 	0
Print mode	Set the print mode. There are 6 modes in total: <ul style="list-style-type: none"> • None: Next label top of form is aligned to the printhead burn line location. (Tear Off Mode) • Batch Mode: Once finishing the printing process, label will be fed to the tear plate location. • Peeler Mode: Enable the label peel off mode. • Cutter Mode: Enable the label cutter mode. • Cutter Batch: Cut the label once at the end of the printing job. • Rewinder Mode: Enable the label rewinder mode. 	Batch Mode
Reprint Mode	Enables/Disables reprint mode. When set to enable, you can reprint the last label printed by pressing the up arrow key . ()	Disable
Offset	Adjust media stop location. Available value setting range: -999 dots to 999 dots.	0 dot
Shift X	Adjust print position. Available value setting range: -999 dots to 999 dots.	0 dot
Shift Y		0 dot
Reference X	Set the origin of printer coordinate system horizontally and vertically. Available setting range: 0 dot to 999 dots.	0 dot
Reference Y		0 dot
Code page	Set the code page of international character set.	850
Country	Set the country code. Available setting value range: 1 to 358.	001

2. ZPL2

This “ZPL2” category can set up the printer settings for ZPL2.

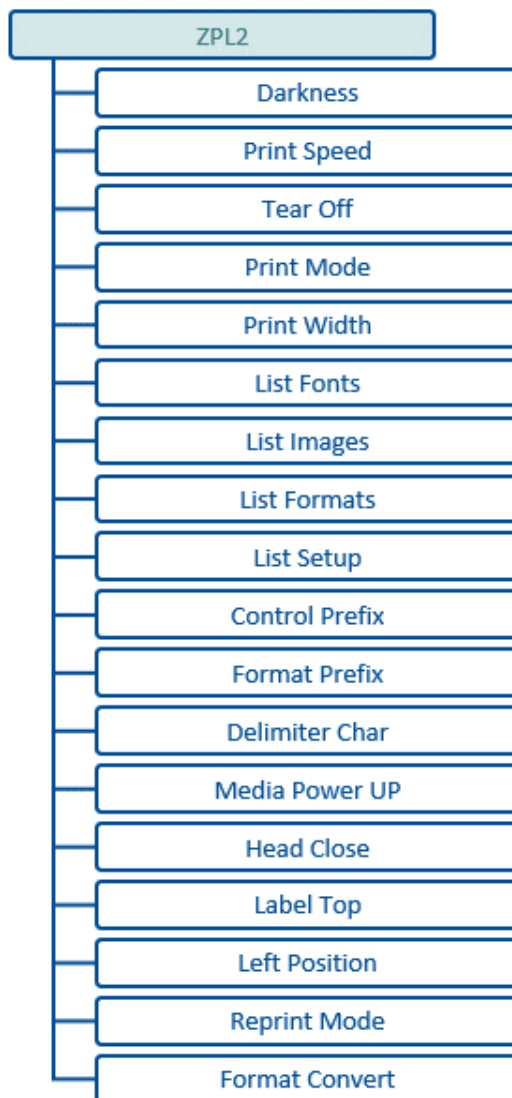

Item	Description	Default
Density	Set the printing darkness. Available setting range: 0 to 30.	16
Print Speed	Set the print speed. Available setting range is 1 to 10 for 203dpi and 1 to 7 for 300dpi.	203 dpi: 5 300 dpi: 3
Tear Off	Adjust media stop location. Available setting value range: -120 to 120 dots.	0 dot
Print mode	Set the print mode. There are 4 modes: <ul style="list-style-type: none"> • Tear Off: Next label top of form is aligned to the printhead heating line location. • Peeler Off: Enable the label peel off mode. • Cutter: Enable the label cutter mode • Rewind: Enable the label rewind mode 	Tear Off
Print Width	Set the print width. Available setting range: 2 to 999 dots.	812 dot
List Fonts	Print the current fonts list from the memory devices to the label.	N/A
List Images	Print current printer available images list stored at the memory device to the label.	N/A
List Formats	Print current printer available formats list from the memory devices to the label.	N/A
List Setup	Print current printer configuration to the label.	N/A
Control Prefix	Set control prefix character.	N/A
Format Prefix	Set format prefix character.	N/A
Delimiter Char	Set delimiter character.	N/A
Media Power Up	Set the action of the media when turning on the printer. <ul style="list-style-type: none"> • Feed: Printer will advance one label. • Calibration: Printer will make calibration. • Length: Printer determine length and feed label. • No Motion: Printer will not move media. 	No Motion
Head Close	Set the action of the media when closing the printhead. <ul style="list-style-type: none"> • Feed: Printer will advance one label. • Calibration: Printer will make calibration. • Length: Printer determine length and feed label. • No Motion: Printer will not move media. 	No Motion
Label Top	Adjust print position vertically on the label. Value range: -120 to +120 dots.	0 dot
Left Position	Adjust print position horizontally on the label. Value range:-9999 to +9999 dots.	0
Reprint Mode	Reprint the last label by pressing up arrow key () on printer's control panel.	Disable
Format Convert	Select the bitmap scaling factor. The first number is the original dots per inch (dpi) value; the second the dpi which you would like to scale. <ul style="list-style-type: none"> • None: No change • 300 -> 600 • 200 -> 600 • 150 -> 600 • 150 -> 300 	None

6.4 Sensor

The setting options in the Sensor menu allows users to calibrate the printer based on what kind of the media they want to use. It is recommended to run the sensor calibration anytime you use a different media.

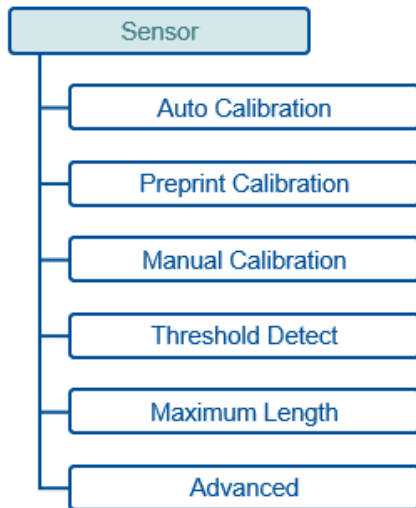

Item	Description	Default
Auto Calibration	Set the media sensor type and calibrate the selected sensor automatically. <ul style="list-style-type: none"> • Gap • Black Mark • Continuous 	N/A
Preprint Calibration	Runs the calibration automatically when using the preprinted labels. <ul style="list-style-type: none"> • Gap • Black Mark 	N/A
Manual Calibration	In case Auto Calibration does not work, please use "Manual" function to set the paper length and gap/black mark size to complete the calibration setting. <ul style="list-style-type: none"> • Gap • Black Mark • Continuous 	N/A
Threshold Detect	Sets the sensor's sensitivity. Setting options: Auto / Fixed.	Auto
Maximum Length	Specifies the maximum length for label calibration. Setting range: 1 to 9999 mm.	253 mm
Advanced	Specifies the minimum label length and the maximum gap or black mark length before running Auto Calibration. <ul style="list-style-type: none"> • Min. Paper (setting range: 0 to 39") • Max. Gap/Mark (setting range: 0 to 39") 	0 mm

6.5 Interface

Interface menu allows users to configure the printer's I/O interfaces.

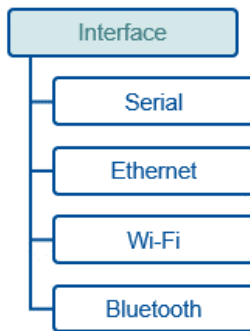

1. Serial COM

The table below describes the configurable items for the printer's RS-232 interface.

Item	Description	Default
Baud Rate	Sets Baud Rate for the RS-232 interface. Setting options: 1200 / 2400 / 4800 / 9600 / 19200 / 38400 / 57600 / 115200 bps.	9600
Parity	Sets parity check for the RS-232 interface. Setting options: None / Even / Odd.	None
Data Bits	Sets the number of bits in a data frame for the RS-232 interface. Setting options: 7 / 8.	8
Stop Bit(s)	Sets the number of stop bits that mark the end of a frame for the RS-232 interface. Setting options: 1 / 2.	1

2. Ethernet

The table below describes the configurable items for the printer's Ethernet interface.

Item	Description	Default
Network Interface	Sets the network interface. Setting options: Ethernet / Wi-Fi. Note: If you have used Wi-Fi interface before, you have to switch to Ethernet here first.	N/A
Status	Displays information about the Ethernet connection if the printer is connected to a wired network.	N/A
Configure	Select to use a DHCP server or non-DHCP server. <ul style="list-style-type: none"> DHCP: Select to use a DHCP (Dynamic Host Configuration Protocol) network protocol. Static IP: Select to use a non-DHCP server. You need to manually enter the IP address, subnet mask, and default gateway. 	N/A

3. Wi-Fi

The table below describes the configurable items for the printer's Wi-Fi connection.

Item	Description	Default
Network Interface	Sets the network interface. Setting options: Ethernet / Wi-Fi. Note: If you are connected to Wi-Fi network before, you have to switch to Wi-Fi here first.	N/A
Status	Displays information about the Wi-Fi connection if the printer is connected to a wireless network.	N/A
Config.	Select to use a DHCP server or non-DHCP server. <ul style="list-style-type: none"> DHCP: Select to use a DHCP (Dynamic Host Configuration Protocol) network protocol. Static IP: Select to use a non-DHCP server. You need to manually enter the IP address, subnet mask, and default gateway. 	DHCP
SSID	Sets SSID for the Wi-Fi connection.	N/A
Security	Sets security type for the Wi-Fi connection.	Open
Password	Sets a password for the Wi-Fi connection.	N/A





4. Bluetooth

The table below describes the configurable items for the Bluetooth interface.

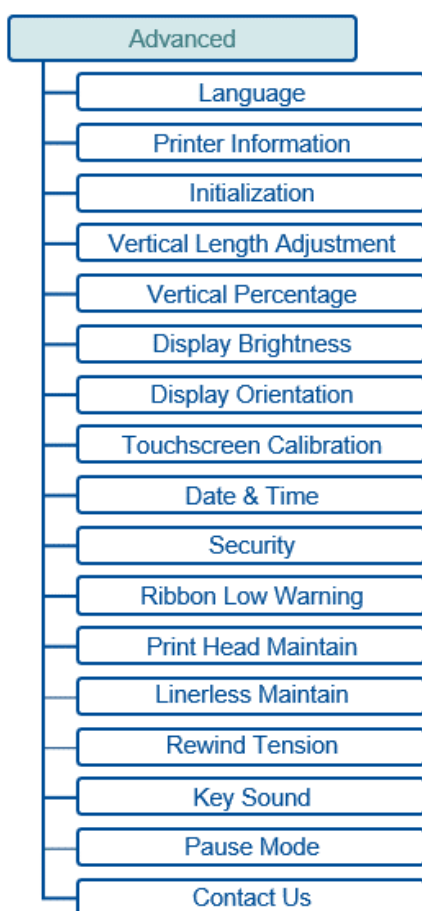
Item	Description	Default
Status	Displays information about the Bluetooth status.	N/A
Local Name	Sets the local name for Bluetooth.	PS-XXXXXX Note: XXXXXX indicates the last six digits of the MAC address. You can find the MAC address in the Status item.
Pair Mode	Sets the pair mode for Bluetooth. <ul style="list-style-type: none">• LEGACY• JUSTWORK Note: This setting item is for MFi module only.	LEGACY
PIN Code	Sets the local ping code for Bluetooth.	0000

6.6 Advanced



Item	Description	Default
Language	Switch the language on display.	English
Printer Information	Check the printer's serial number, printed mileage (m), printed labels (pcs) and cutting counter.	N/A
Initialization	Reset printer settings to factory defaults.	N/A
Vertical Length Adjustment	Turn on/off the Vertical Length Adjustment function.	OFF
Vertical Percentage	Adjust the label length. Setting range: 90 to 115%. Note: This subsection will only be visible when the "Vertical Length Adjustment" item is turned on.	100
Display Brightness	Set the brightness for display. Setting range: 0 to 100.	50
Display Orientation	Set the orientation for the display. Setting options: 0 / 180.	0
Touchscreen Calibration	Calibrate the touchscreen for best result.	N/A
Date & Time	Setup the date and time on display. <ul style="list-style-type: none"> Date Format: Set the date display format. (YYYY/MM/DD, DD/MM/YYYY, MM/DD/YYYY, YYYY-MM-DD, DD-MM-YYYY, MM-DD-YYYY) Date: Adjust the date. Time Format: Set the time display format. (12 hr/ 24 hr) Time: Set the time. 	N/A
Security	Set the password for locking the menu and the favorites. Default password: 8888.	Disable
Ribbon Low Warning	Set the warning for ribbon low. For example, if setting value is 30m, when ribbon capacity was lower than 30m, the number of meters remaining next to the icon () will be shown in red. Setting range: 10 to 100 m.	30m
Print Head Maintain	Check printhead status and to set the settings for printhead care. <ul style="list-style-type: none"> Warning: Turn on/off the printhead maintenance warning. If enable this feature, once printhead has been reached the setting mileage then the warning icon () will be shown on printer UI for reminding user to clean the printhead. Default setting: OFF. Reset Counter: Reset the printhead clean warning mileage after cleaning printhead. Interval: Set mileage count for the printhead. When the set amount of mileage is fulfilled, the warning icon that reminds users to clean the printhead will appear on the display panel. Default setting: 1 km. 	N/A
Linerless Maintain	Set how often the linerless cutter blade should be cleaned. <ul style="list-style-type: none"> Warning: Turns on/off notification that reminds users to clean the cutter blade if the set mileage for the cutter blade is fulfilled. Default setting: ON. Interval: Sets mileage for the cutter blade. When the set amount of mileage is fulfilled, the warning icon () that reminds users to clean the cutter blade will appear on the display panel. Default setting: 1 km. Clean Cutter Blade: Lifts up to expose the cutter blade. Select this item to lift up the cutter blade if you need to clean the blade. (Linerless cutter printer only) NOTE: For how to clean the linerless cutter blade, please refer to Maintenance for more information. CAUTION: To avoid the risk of personal injury, keep your hands away from the cutter gate when selecting Clean Cutter Blade. Selecting this item will lift up the blade. Reset Counter: Resets the mileage count after cleaning the cutter blade. Note: <ul style="list-style-type: none"> These options can also be quickly accessed directly from "Favorites" (touch LCD only) to set them up. This subsection will only be visible when the linerless module installed. 	N/A
Rewind Tension	Set the ribbon rewind tension %. Setting range: -50 to 50%.	0%
Key Sound	Turns on/off the sounds when tapping the touchscreen or pressing the function buttons.	ON
Pause Mode	This item is used to enable/disable the printer into pause mode (Off line). After selecting "enable", press the down arrow key () and the printer will pause all actions.	Disable
Contact us	Check the contact information for tech support service	N/A

6.7 File Manager

File Manager allows users to check the remaining space of the printer’s built-in memory and manage or execute the files saved in the printer’s DRAM/Flash memory or micro SD card.

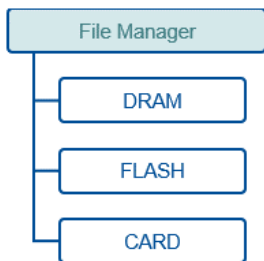

Item	Description
DRAM	Allows users to manage or execute files (.BAS) saved in the printer’s DRAM.
FLASH	Allows users to manage or execute files (.BAS) saved in the printer’s Flash memory.
CARD	Allows users to manage or execute files (.BAS) saved in the micro SD card. Note: This subsection will only be visible when the SD card installed.

6.8 Diagnostic

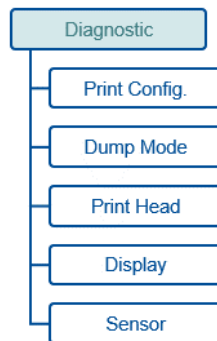

Item	Description
Print Config.	Print current printer configuration to the label. The configuration printout contains printhead test pattern, which is useful for checking the dot damage on the printhead heater.
Dump Mode	Captures the data from the communications port and prints out the data received by printer. In the dump mode, all characters will be printed in 2 columns. The left side characters are received from your system and right side data are the corresponding hexadecimal value of the characters. It allows users or engineers to verify and debug the program. Note: Dump mode requires 4” wide paper width.
Printhead	Check printhead’s temperature and bad dots.
Display	Check LCD’s color state.
Sensor	Check sensors intensity and reading state.

6.9 Favorites (Touch LCD Only)

Favorites helps users build a commonly used list. Arrange the commonly used settings .



- **Add items:** Touch and hold the item > window of **Join Favorites** will pop up > tap **Yes** to add the item to **Favorites**.

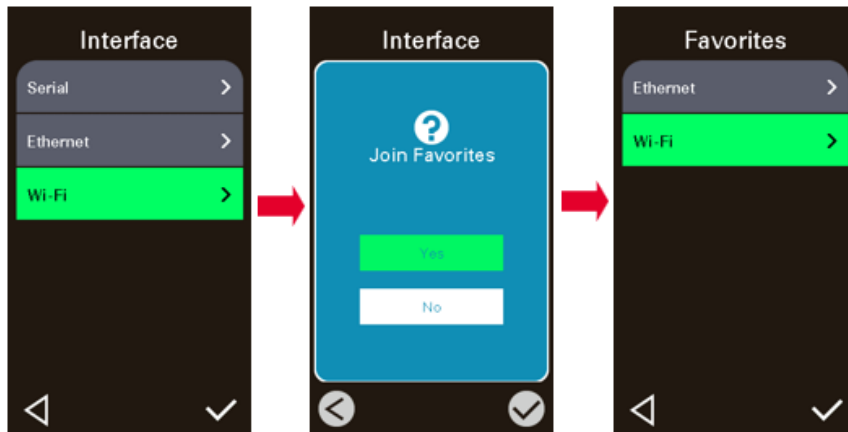

- **Delete items:** Touch and hold the item > window of **Delete Favorites** will pop up > tap **Yes** to delete the item.

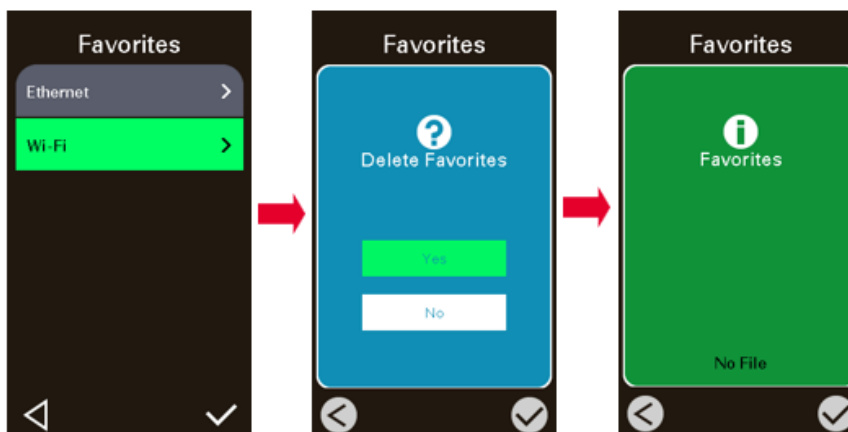

6.10 Linerless Media Printer Configuration

1. After loading the linerless media into the printer, perform the calibration  to calibrate the media sensor (Continuous).
2. When the calibration is finished, enter the printer LCD Menu to configure the linerless printer. Select **Setting**. Make sure the Command Set is set to **TSPL**. For linerless tear module, select **Print Mode** and set the print mode to **Peeler Mode**. For linerless cutter module, select **Print Mode** and set the print mode to **Cutter Mode**.

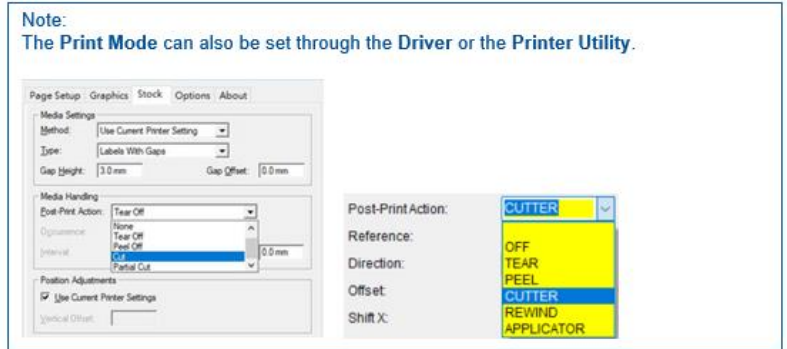
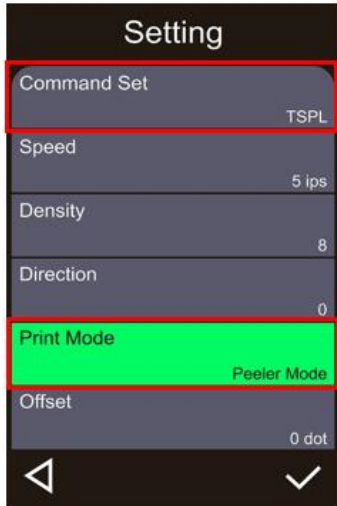

The following paragraph describes the setting options that help optimize the print quality when using the linerless media. The setting options will automatically appear in the Favorites folder (touch LCD only) after installing the linerless cutter/tear-off module onto the printer. (for 2.3" LCD models, refer to [Advanced](#) section)

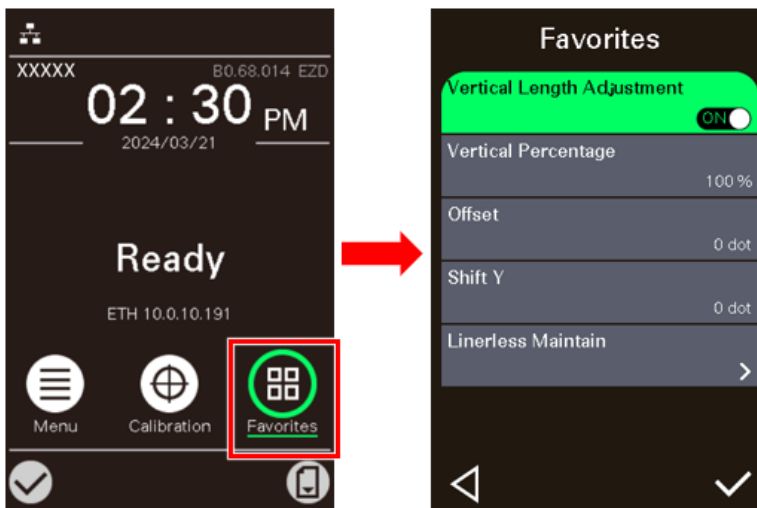

Item	Description
Vertical Length Adjustment	Turns on/off the Vertical Length Adjustment function. Setting option: ON / OFF .
Vertical Percentage	Adjusts the label length. This item will not appear if Vertical Length Adjustment is turned off. Setting range: 90 to 115%.
Offset	Specifies the stop position for each operation. Setting range: -203 to 203 dots.
Shift Y	Specifies the amount to shift an image vertically up or down for precise print position on the label. Setting range: -203 to 203 dots.
Linerless Maintain	<p>Sets how often the printer should be cleaned after printing with the linerless media.</p> <p>Warning: Turns on/off notification that reminds users to clean the printer if the set mileage is fulfilled. Default setting: ON.</p> <p>Interval: Schedules printer maintenance after printing with the linerless media. When the set amount of mileage is fulfilled, the warning icon (🔧) that reminds users to clean the printer will appear on the display panel. Default setting: 1 km.</p> <p>Clean Cutter Blade: Lifts up to expose the cutter blade. Select this item to lift up the cutter blade if you need to clean the blade.</p> <p>NOTE: Clean Cutter Blade will be displayed in the menu after installing the cutter module on the printer. For how to clean the linerless cutter blade, please refer to Maintenance for more information.</p> <p>CAUTION: To avoid the risk of personal injury, keep your hands away from the cutter gate when selecting Clean Cutter Blade. Selecting this item will lift up the blade.</p> <p>Reset Counter: Resets the mileage count after cleaning the printer.</p>

7.0 Troubleshooting

The following guide lists the most common problems that may be encountered when operating this bar code printer. If the printer still does not function after all suggested solutions have been invoked, please contact the Customer Service Department of your purchased reseller or distributor for assistance.

Problem	Possible Cause	Recovery Procedure
Power indicator does not illuminate	<ul style="list-style-type: none"> * The power cord is not properly connected. * The power switch is off. 	<ul style="list-style-type: none"> * Plug the power cord in printer and outlet. * Switch the printer on.
Carriage Open	<ul style="list-style-type: none"> * The printer carriage is open. 	<ul style="list-style-type: none"> * Please close the print carriage.
Not Printing	<ul style="list-style-type: none"> * Check if interface cable is securely connected to the interface connector. * Check if wireless or Bluetooth device is connected between host and printer. * The port specified in the Windows driver is not correct. 	<ul style="list-style-type: none"> * Re-connect cable to interface or change to a new cable. * Please reset the wireless device settings. * Select the correct printer port in the driver. * Clean the printhead. * Printhead's harness connector is not securely connected with printhead. Turn off the printer and re-plug the connector again. * Check your program if there is the command PRINT at the end of the file and there must have CRLF at the end of each command line.
No print on the label	<ul style="list-style-type: none"> * Label or ribbon is not loaded correctly. * Using wrong type media or ribbon 	<ul style="list-style-type: none"> * Follow the instructions in loading the media and ribbon. * Ribbon and media are not compatible. * Verify the ribbon-inked side. * The print density setting is incorrect.
No Ribbon	<ul style="list-style-type: none"> * Running out of ribbon. * The ribbon is installed incorrectly. 	<ul style="list-style-type: none"> * Supply a new ribbon roll. * Please refer to the steps in user's manual to reinstall the ribbon.
No Paper	<ul style="list-style-type: none"> * Running out of label. * The label is installed incorrectly. * Gap/black mark sensor is not calibrated. 	<ul style="list-style-type: none"> * Supply a new label roll. * Please refer to the steps in user's manual to reinstall the label roll. * Calibrate the gap/black mark sensor.
Paper Jam	<ul style="list-style-type: none"> * Gap/black mark sensor is not set properly. * Make sure label size is set properly. * Labels may be stuck inside the printer mechanism. 	<ul style="list-style-type: none"> * Calibrate the media sensor. * Set media size correctly. * Remove the stuck label inside the printer mechanism.
Take Label	<ul style="list-style-type: none"> * Peel function is enabled. 	<ul style="list-style-type: none"> * If the peeler module is installed, please remove the label. * If there is no peeler module in front of the printer, please switch off the printer and install it. * Check if the connector is plugged in correctly.

Unable to use microSD card	<ul style="list-style-type: none"> * microSD card is damaged. * microSD card doesn't insert correctly. * Using a non-approved SD card manufacturer. 	<ul style="list-style-type: none"> * Use the supported capacity microSD card. * Insert the microSD card again. * For supported microSD card specs and the approved microSD card manufacturers, please refer to section 2.2.3.
Poor Print Quality	<ul style="list-style-type: none"> * Ribbon and media are loaded incorrectly * Dust or adhesive accumulation on the printhead. * Print density is not set properly. * Printhead element is damaged. * Ribbon and media are incompatible. * The printhead pressure is not set properly. 	<ul style="list-style-type: none"> * Reload the supply. * Clean the printhead. * Clean the platen roller. * Adjust the print density and print speed. * Run printer self-test and check the printhead test pattern and see if there is a dot missing in the pattern. * Change to proper ribbon or proper label media. * Adjust the printhead pressure adjustment knob. * The release lever does not latch the printhead properly.
Missing printing on the left or right side of label	<ul style="list-style-type: none"> * Wrong label size setup. 	<ul style="list-style-type: none"> * Set the correct label size.
Gray line on the blank label	<ul style="list-style-type: none"> * The printhead is dirty. * The platen roller is dirty. 	<ul style="list-style-type: none"> * Clean the printhead. * Clean the platen roller. (Please refer to chapter 9)
Irregular printing	<ul style="list-style-type: none"> * The printer is in Hex Dump mode. * The RS-232 setting is incorrect. 	<ul style="list-style-type: none"> * Turn the printer off and on to skip the dump mode. * Re-set the Rs-232 settings.
Label feeding is not stable (skewed) when printing	<ul style="list-style-type: none"> * The media guide does not touch the edge of the media. 	<ul style="list-style-type: none"> * If the label is moving to the right side, please move the label guide to the left. * If the label is moving to the left side, please move the label guide to the right.
Skip labels when printing	<ul style="list-style-type: none"> * Label size is not specified properly. * Sensor sensitivity is not set properly. * The media sensor is covered with dust. 	<ul style="list-style-type: none"> * Check if label size is setup correctly. * Calibrate the sensor by Auto Gap or Manual Gap options. * Clear the GAP/Black mark sensor by using a blower or brush.
Wrinkle Problem	<ul style="list-style-type: none"> * Printhead pressure is incorrect. * Ribbon installation is incorrect. * Media installation is incorrect. * Print density is incorrect. * Media feeding is incorrect. 	<ul style="list-style-type: none"> * Please refer to the next chapter. * Please set a suitable density to have good print quality. * Make sure the label guide touches the edge of the media.
RTC time is incorrect when rebooting the printer	<ul style="list-style-type: none"> * The battery has run down. 	<ul style="list-style-type: none"> * Check if there is a battery on the main board.
The left side printout position is incorrect	<ul style="list-style-type: none"> * Wrong label size setup. * The parameter Shift X in LCD menu is incorrect. 	<ul style="list-style-type: none"> * Set the correct label size. * Press [Menu] → [Setting] → [Shift X] to fine tune the parameter of Shift X.

<p>The printing position of a small label is incorrect</p>	<ul style="list-style-type: none">* Media sensor sensitivity is not set properly.* Label size is incorrect.* The parameter Shift Y in the LCD menu is incorrect.* The vertical offset setting in the driver is incorrect.	<ul style="list-style-type: none">* Calibrate the sensor sensitivity again.* Set the correct label size and gap size.* Press [Menu] → [Setting] → [Shift Y] → to fine tune the parameter of Shift Y.* If using the software BarTender, please set the vertical offset in the driver.
---	--	---

8.0 Maintenance

This session presents the cleaning tools and methods to maintain your printer.

1. Please use one of following materials to clean the printer.

- Cotton swab
- Lint-free cloth
- Vacuum / Blower brush
- 100% Ethanol or Isopropyl Alcohol

2. The cleaning process is described as following,

Printer Part	Method	Interval
Printhead	1. Always turn off the printer before cleaning the printhead. 2. Allow the printhead to cool for a minimum of one minute. 3. Use a cotton swab and 100% Ethanol or Isopropyl Alcohol to clean the printhead surface.	Clean the printhead when changing a new label roll.
	<p>The diagram illustrates the cleaning process of the printhead. It shows a side view of the printhead assembly with a cleaning pen being used to clean the printhead element. Labels include: Printhead, Element, and Cleaning Pen. A detailed inset view shows the printhead element with a label 'Printhead' and 'Element' pointing to the specific part being cleaned.</p>	
Platen Roller	1. Turn the power off. 2. Rotate the platen roller and wipe it thoroughly with water.	Clean the platen roller when changing a new label roll
Peel Bar	Use a lint-free cloth with 100% ethanol to wipe it.	As needed
Sensor	Compressed air or vacuum	Monthly
Exterior	Wipe it with water-dampened cloth	As needed
Interior	Brush or vacuum	As needed

Note:

- Do not touch printhead by hand. If you touch it accidentally, please use ethanol to clean it.
- Please use 100% Ethanol or Isopropyl Alcohol. DO NOT use medical alcohol, which may damage the printhead.
- Regularly clean the printhead and supply sensors when changing to a new media to keep printer performance good and extend printer life.



Corporate Headquarters

3222 Corte Malpaso, Suite-208
Camarillo, CA 93012
TEL: 800.215.9192
FAX: 805.484.5282
Web site: www.AMTDatasouth.com

Manufacturing/Service

5033 Sirona Drive, Suite-800
Charlotte, NC 28273
TEL: 800.476.2120
FAX: 704.525.6104
