

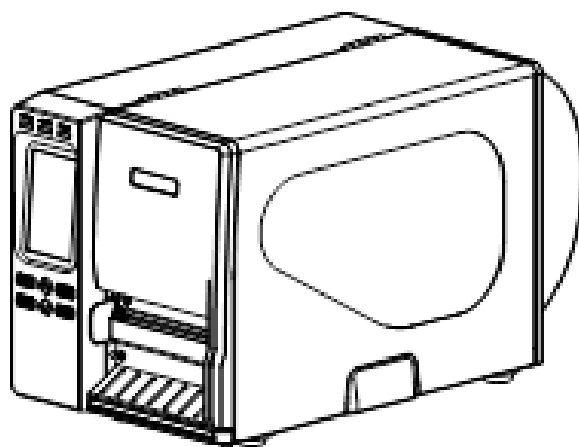

Fastmark M7XPd
Thermal Barcode Printer
(Direct & Transfer)

User's Guide



Copyright Declaration

Information in this manual is subject to change without notice and does not represent a commitment on the part of AMT Datasouth Corporation. No part of this manual may be reproduced or transmitted in any form by any means, for any purpose other than the purchaser's personal use, without the expressed written permission of AMT Datasouth Corporation.

Trademark Credits:

- CG is a registered trademark of Agfa Corporation.
- CG Triumvirate Bold Condensed font is under license from the Monotype Corporation.
- Windows is a registered trademark of Microsoft Corporation.
- All other trademarks are property of their respective owners.

Regulatory Statement:

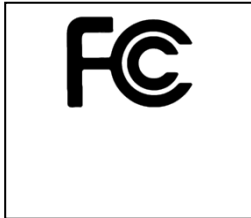

FCC CFR Title 47 Part 15B, Class A ICES-003, Class A

This equipment has been tested and found to comply with the limits for a Class A digital device, pursuant to Part 15 of the FCC Rules. These limits are designed to provide reasonable protection against harmful interference when the equipment is operated in a commercial environment.

This equipment generates, uses, and can radiate radio frequency energy and, if not installed and used in accordance with the manufacturer's instruction manual, may cause harmful interference with radio communications. Operation of this equipment in a residential area is likely to cause harmful interference, in which case you will be required to correct the interference at your own expense.



This Class A digital apparatus complies with Canadian ICES-003. Cet appareil numérique de la classe A est conforme à la norme NMB-003 du Canada.

UL 60950-1 (2nd Edition)
CSA C22.2 No.60950-1-07 (2nd Edition)
120VAC ~ 60Hz ~ 2.0A



CE CLASS A
EN 55022, EN 55024
EN 61000-3-2 / EN 61000-3-3
EN 60950-1



EN 60950-1/A1:2010



AS/NZS CISPR 22 (Class A)



Table of Contents

User Caution.....	5
Packaging.....	6
Unpacking the printer	6
Removing protective material	6
Introduction.....	7
Product	7
Model configuration	7
Printer Overview	8
Front view	8
Interior view	9
Rear view.....	10
Operator Controls.....	11
Display panel	11
Indicators	11
Key functions	12
Touch Screen	12
Installation.....	14
Setting up the printer	14
Loading ribbon.....	14
Removing used ribbon.....	17
Loading media roll	19
Loading fan fold media	24
Loading media in peel mode	25
Adjusting print head pressure.....	28
Print head burn line adjustment:.....	29
Ribbon flow adjustment (wrinkle removal):.....	30
Control Panel.....	32
LCD Menu.....	32
Main Menu Overview.....	32
PAL™ Print and Program Overview	46
PALSECURE ON DEMAND™	46
Traditional Printing.....	46
Legacy Data Stream Interpretation.....	46
Standalone/Downtime Applications	47

Table of Contents

- Diagnostic Tool.....49**
- Start Diagnostic Tool49
- Printer Function50
- Setting Ethernet by Diagnostic Utility50
- Using USB interface to setup Ethernet interface.....51
 - Using RS-232 interface to setup Ethernet interface.....52
 - Using Ethernet interface to setup Ethernet interface53

- Troubleshooting.....55**
- Common Problems55

- Maintenance59**
- Tools and Methods59

Operational safety



CAUTION

- Refer to the product label (back of the printer) and verify your power source exactly meets those requirements.
- Mechanical and electrical repairs should be conducted by qualified service personnel.
- Do not use this product near heat or water.
- Unplug this product from the power outlet before cleaning.

Cautions in setting up



ATTENTION

- Unpack the printer. Make sure that the printer body and all accessories are included in the package and no parts are damaged.
- Any changes or modifications not expressly approved by the grantee of this device could void the user's authority to operate the equipment.
- Do not use the printer in a location exposed to direct sunlight or close to a heater or other heat generating equipment.
- Before connecting or disconnecting the interface cable, be sure to turn off the printer.
- Place the printer on a rigid, horizontal base in a location that is free of vibration.
- Hazardous moving parts in cutter module. Keep finger(s) and other body parts away.
- Refer to print adjustments in this manual before attempting alignments.
- The main circuit board includes real time clock feature and has lithium battery CR2032 installed. Risk of explosion if battery is replaced by an incorrect type. Dispose of used batteries according to the manufacturer instructions.
- Do not turn off the printer during printing, as this may lead to a malfunction.

“VORSICHT”

Explosionsgefahr bei unsachgemäßen Austausch der Batterie. Ersatz nur durch denselben oder einem vom Hersteller empfohlenem ähnlichen Typ. Entsorgung gebrauchter Batterien nach Angaben des Herstellers.

Any changes or modifications not expressly approved by the grantee of this device could void the user's authority to operate the equipment.

Packaging

Unpacking the printer

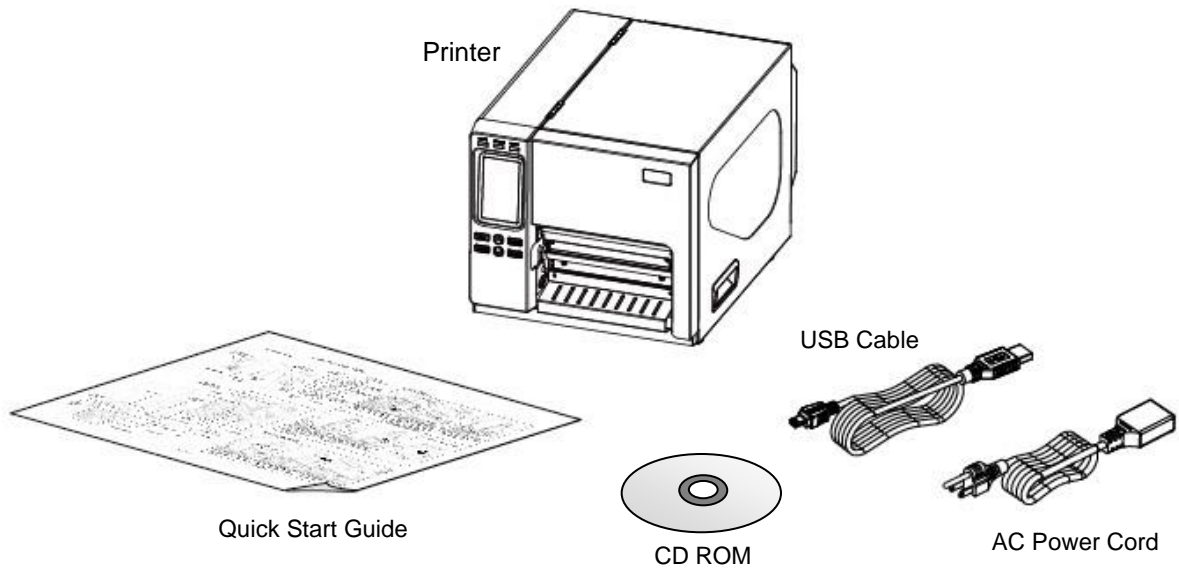

Removing protective material

1. Open the packing box, remove the printer. Open right cover and remove foam block from printhead assembly. Remove paper between printhead and platen.
2. If any parts are missing, please contact the Customer Service Department of your purchased reseller or distributor.
3. It is recommended to keep packaging materials for future use if needed.

Introduction

Product

Thank you for purchasing your AMT Datasouth bar code printer.

This printer is designed with a die-cast aluminum chassis and print mechanism, metal cover with large clear media view window, which ensures it working in extreme and heavy duty industrial environments and applications.

With touch color display, printer status can be managed easier and operated more user friendly. The moveable sensor design can accept a wide range of label media. All of the most frequently used bar code formats are included. Fonts and bar codes can be printed in any one of the four directions.

This printer has built-in the high quality, high performance MONOTYPE IMAGING® True Type font engine and one CG Triumvirate Bold Condensed smooth font. With flexible firmware design, user can also download the True Type Font from their PC into printer memory for printing labels. Besides the scalable font, it also provides a choice of five different sizes of alphanumeric bitmap font, OCR-A and OCR-B fonts. By integrating rich features, it is the most cost-effective and high performance printer in its class!

- | | |
|----------------------------------|----------------------------|
| ❖ Applications | ❖ Industrial-duty printing |
| ❖ Healthcare patient safety | ❖ Compliance labeling |
| ❖ Work in process | ❖ Order fulfillment |
| ❖ Distribution | ❖ Distribution |
| ❖ Shipping/ receiving | ❖ Ticketing |
| ❖ Electronics & jewelry labeling | |

Model configuration

- ❖ Memory 128MB/128MB +SD Card
- RS-232, Centronics, USB, USB Host, Internal Ethernet
- ❖ 203/300 & 600dpi
- ❖ 14ips max
- ❖ Print Length 450in

Printer Overview

Front view



1. LED indicators
2. Touch screen
3. Front panel buttons
4. Media view window
5. Paper exit chute
6. Printer right side cover

Interior view

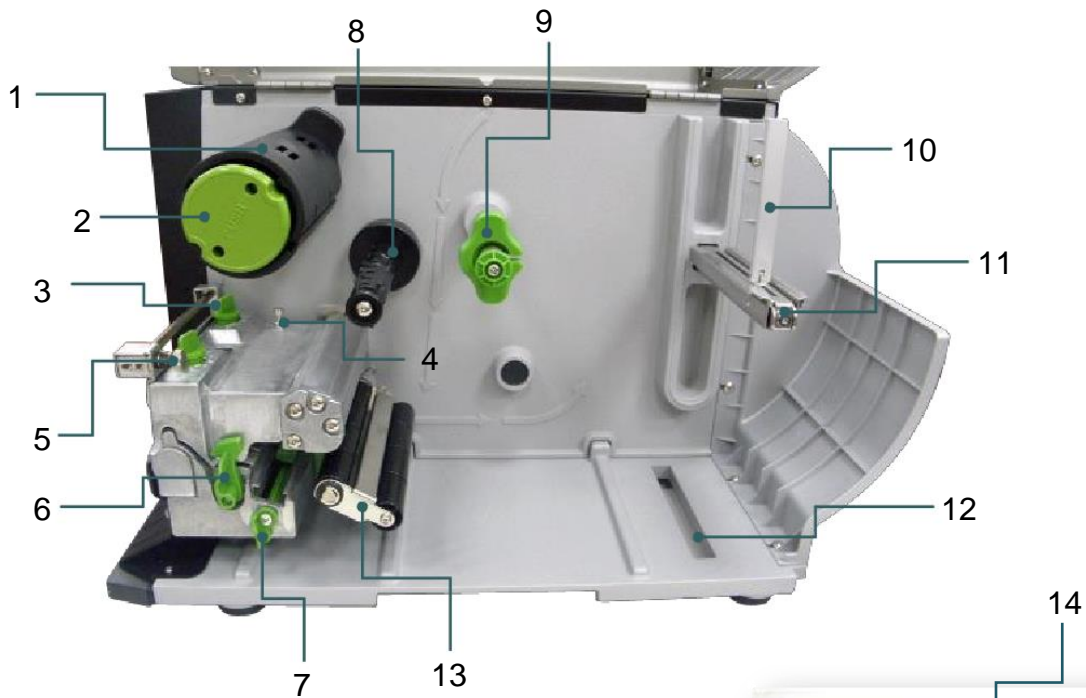

1. Ribbon rewind spindle
2. Ribbon release button
3. Print head pressure adjustment knobs
4. Z axis mechanism adjustment knob
5. Ribbon tension adjustment knob
6. Print head release lever
7. Media sensor lock knob
8. Ribbon supply spindle
9. Media guide bar & Rear label guide
10. Label roll guard
11. 3" label entrance chute
12. External label entrance chute
13. Damper

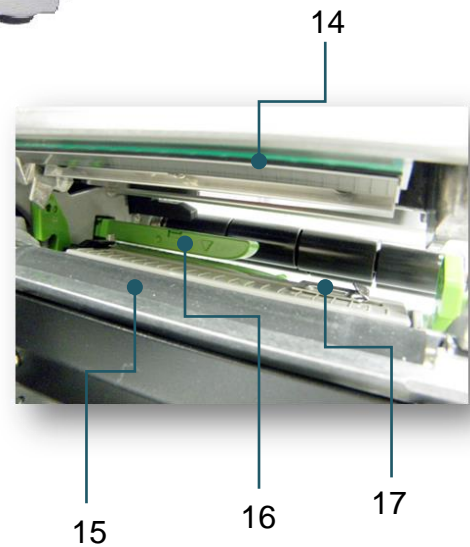

14. Print head
15. Platen roller
16. Media sensor
17. Front label guide

Rear view

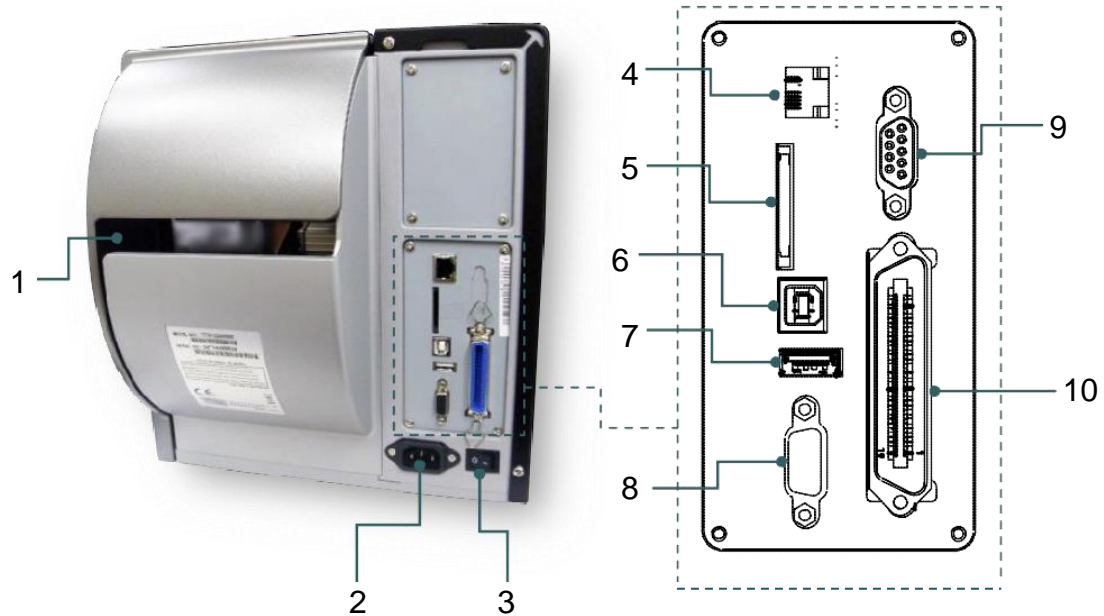

1. External label entrance chute
2. Power cord socket
3. Power switch
4. Ethernet interface
5. *SD card socket
6. USB interface
7. USB host
8. RS-232C interface
9. GPIO interface (Optional)
10. Centronics interface

Note:

- ❖ The above interface picture is for reference only. Please refer to the product specification for the interfaces availability.
- ❖ SD card slot, Ethernet interface and USB Host interface are standard interfaces for “M7XP” models.
- ❖ GPIO interface is optional.

Operator Controls



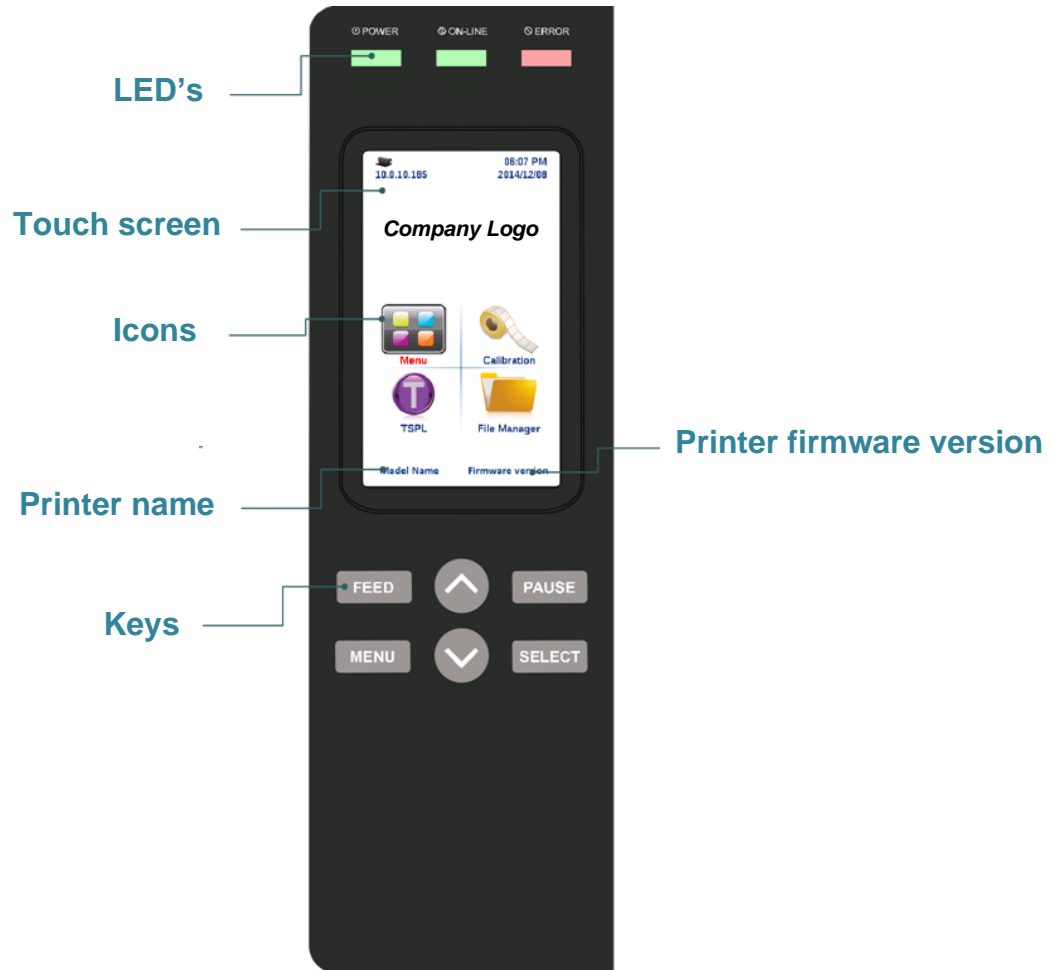

Display panel



Indicators

LED	Status	Indication
POWER	Off	The printer power is turned off
	On	The printer power is turned on
ON-LINE	On	Printer is ready
	Blinking	Pause Downloading data into printer
ERROR	Off	Printer is ready
	On	"Carriage Open" or "Cutter Error"
	Blinking	"No Paper", "Paper Jam", "No Ribbon" or "Clean Data"

Key functions

Key	Function
 MENU	1. Enter the menu 2. Exit from a menu or cancel a setting and return to the previous menu
 PAUSE	Pause/Resume the printing process
 FEED	Advance one label
UP 	Scroll up the menu list
DOWN 	Scroll down the menu list
SELECT	Enter/Select cursor located option

Touch Screen

Tap a menu icon to open and use.

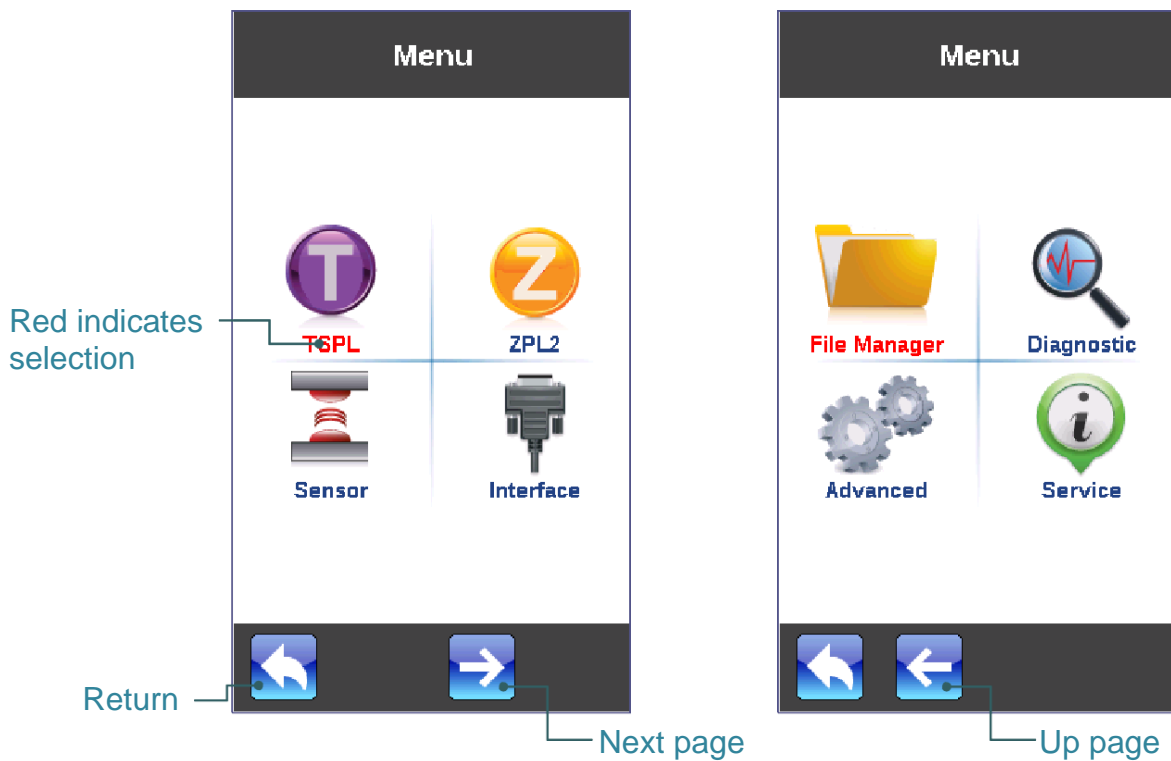

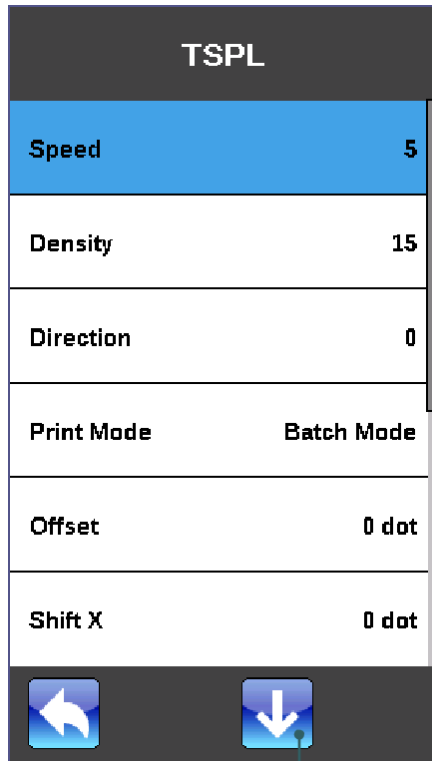

Scroll down

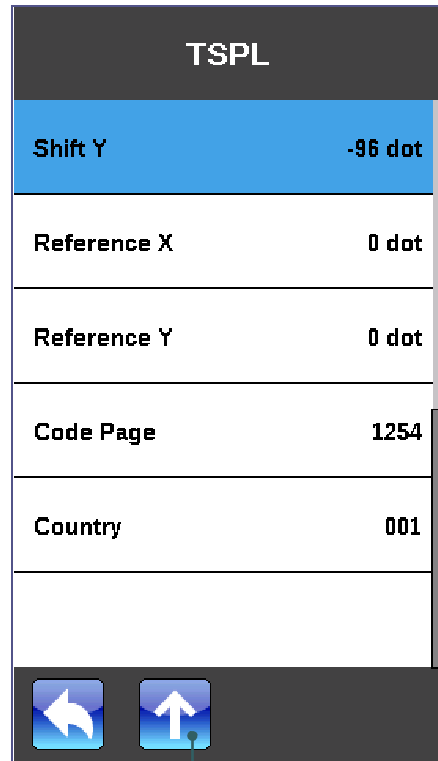

Scroll up

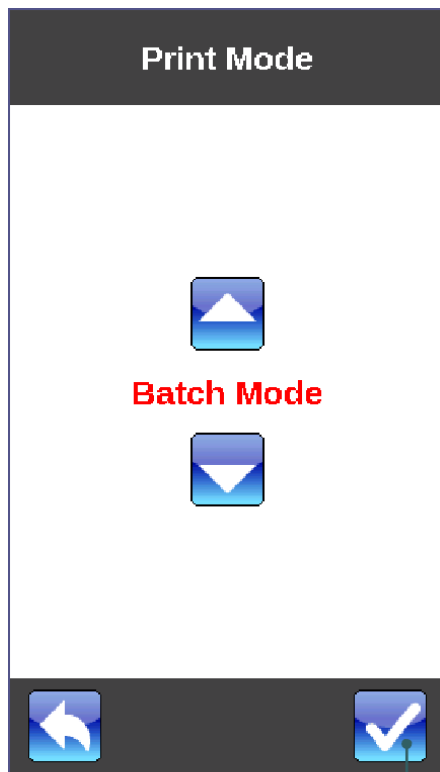

Set

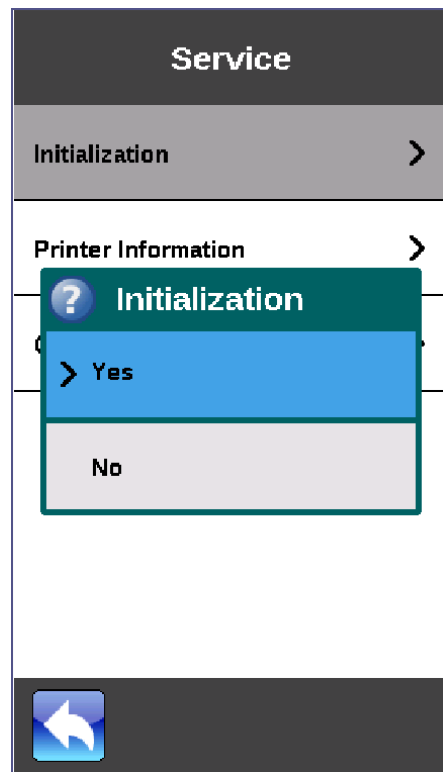

Installation

Setting up the printer

1. Place the printer on a flat, secure surface.
2. Make sure the power switch is off.
3. Connect the printer to the computer with the provided USB cable.
4. Plug the power cord into the AC power cord socket at the rear of the printer, and then plug the power cord into a properly grounded power outlet.



Verify the printer power switch is in the OFF position before installing the power cord.

Loading ribbon

1. Open the printer right side cover.



2. Push the release lever to open the print head mechanism.

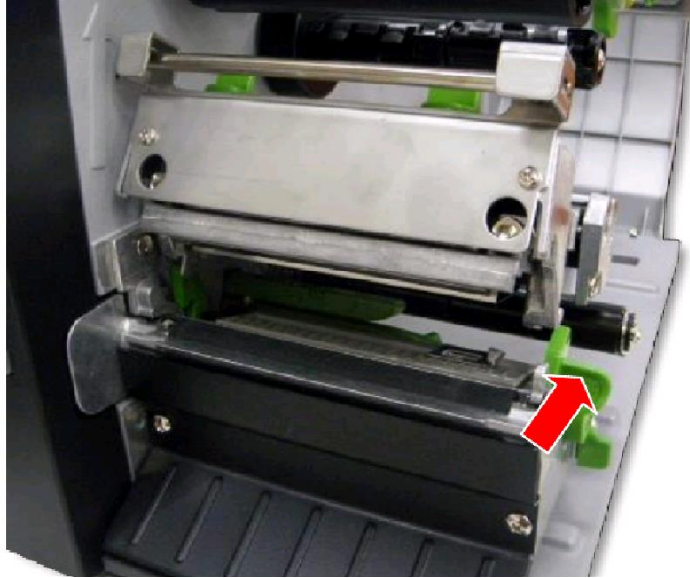

3. Install the ribbon onto the supply spindle.

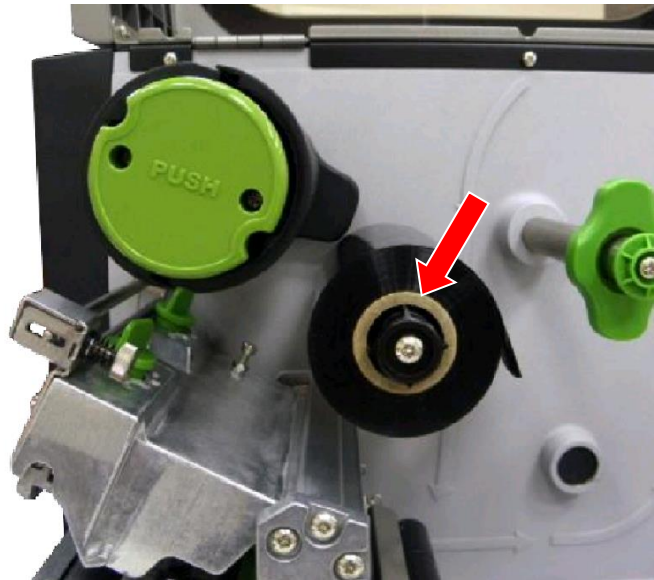

Do Not push the release button when installing the ribbon. The release button is only used when removing the ribbon.

4. Thread the ribbon through the sensor slot, and then through the open space in between printhead and platen.

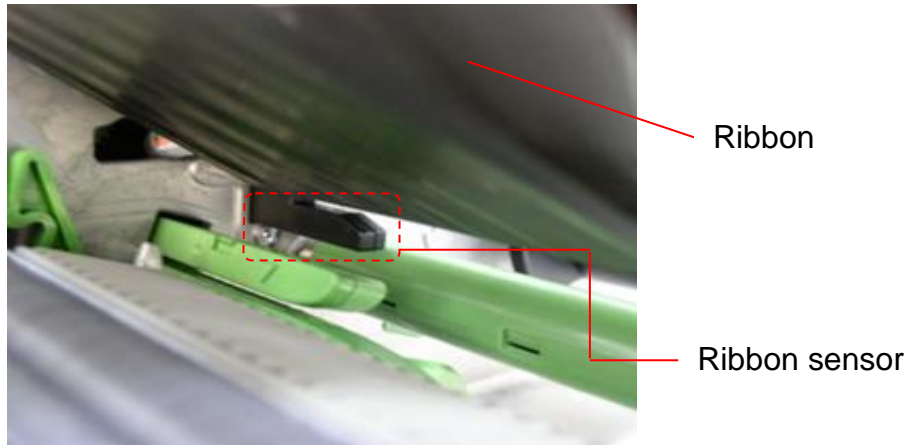

5. Wrap the ribbon onto the rewind spindle. Turn the spindle clockwise 3~5 complete turns. Verify the ribbon is properly stretched/flat without wrinkles.

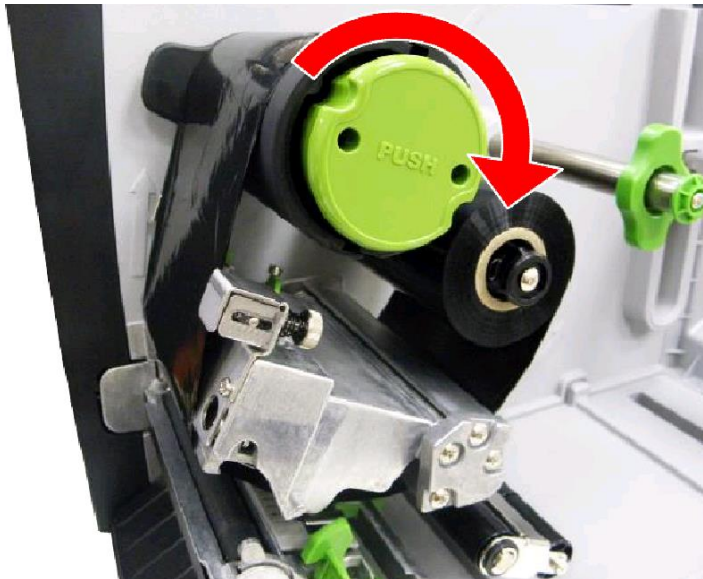

Do Not push the release button when installing the ribbon. The release button is only used when removing the ribbon.

6. Close the print head mechanism making sure the latches are engaged securely.

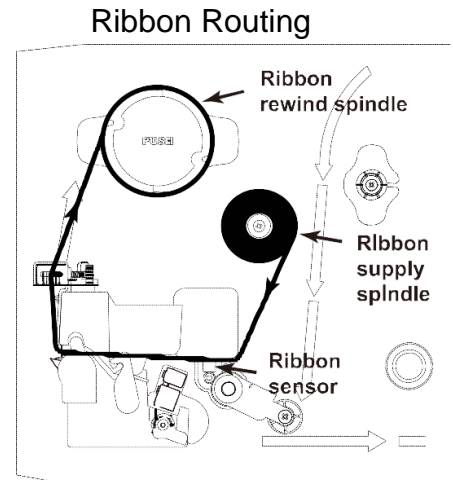
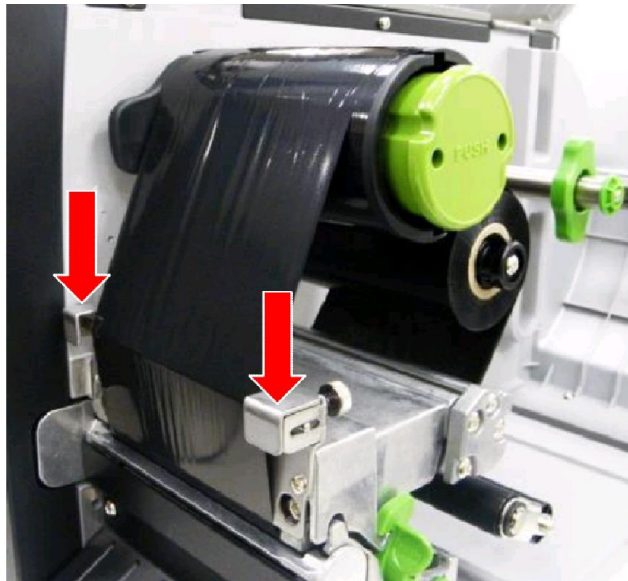

Removing used ribbon

1. Cut ribbon between guide and rewind spindle.



2. Push green button to release ribbon from the spindle.



3. Pull off used ribbon.



Loading media roll

1. Open the printer right side cover.



2. Push the printhead release lever to open the mechanism.

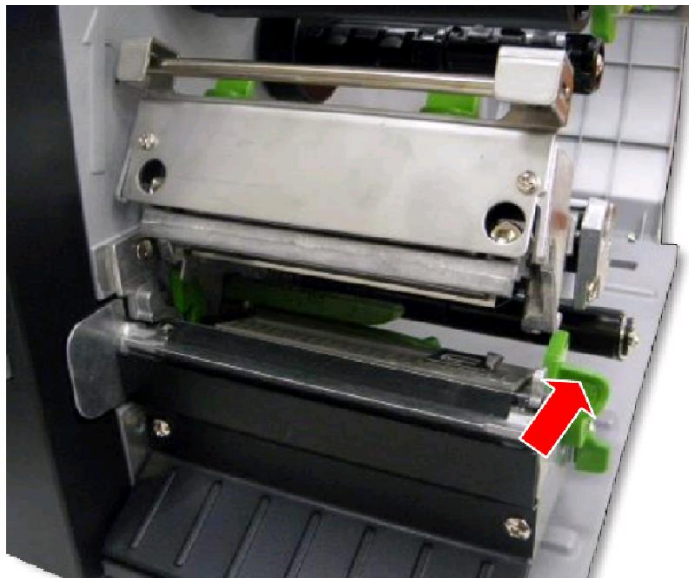

3. Move the label guard across the spindle and lay it down horizontally.

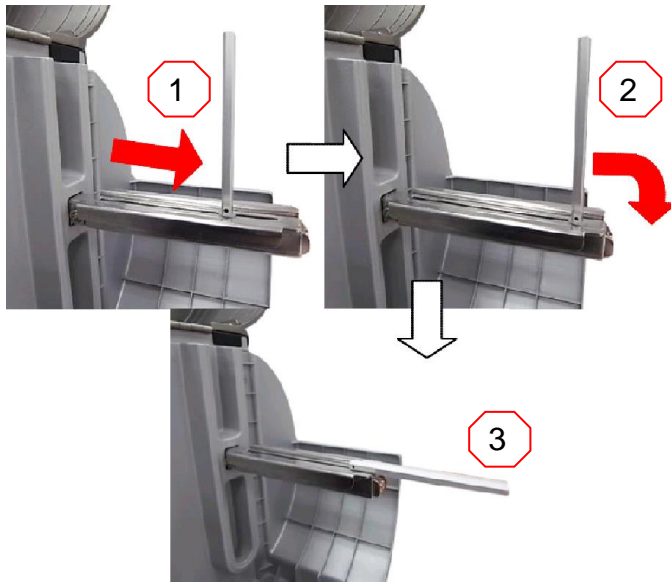

4. **NOTE:** The 3" label spindle can be removed to support a 1" core, by removing two screws.

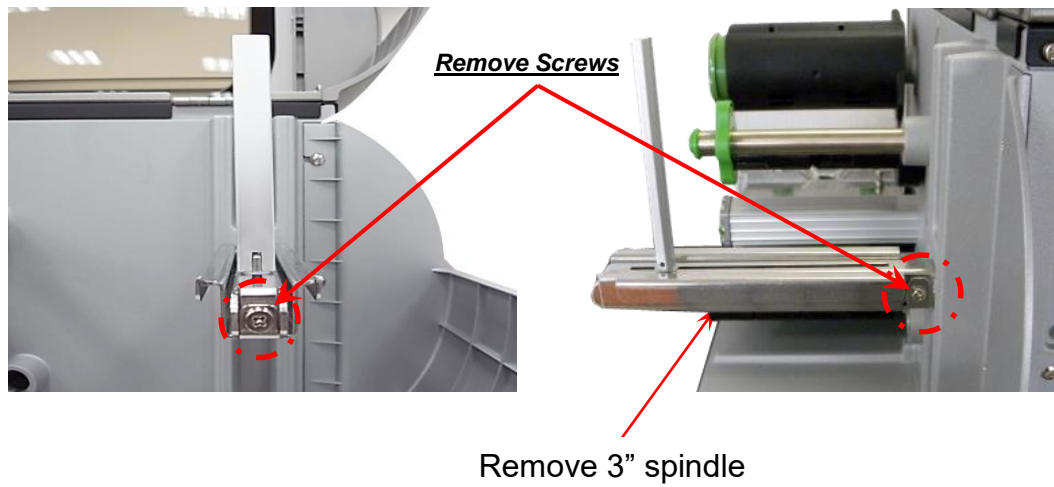

5. Place the roll of media onto the supply spindle, positioning it to the back of the chassis. Lift and position the label guard against the roll of media.



6. Pull leading edge of label forward over the media guide bar, under the damper, through the media sensor (green) and place the label onto the platen roller. Adjust the rear label guide (green) to fit the width of the label.

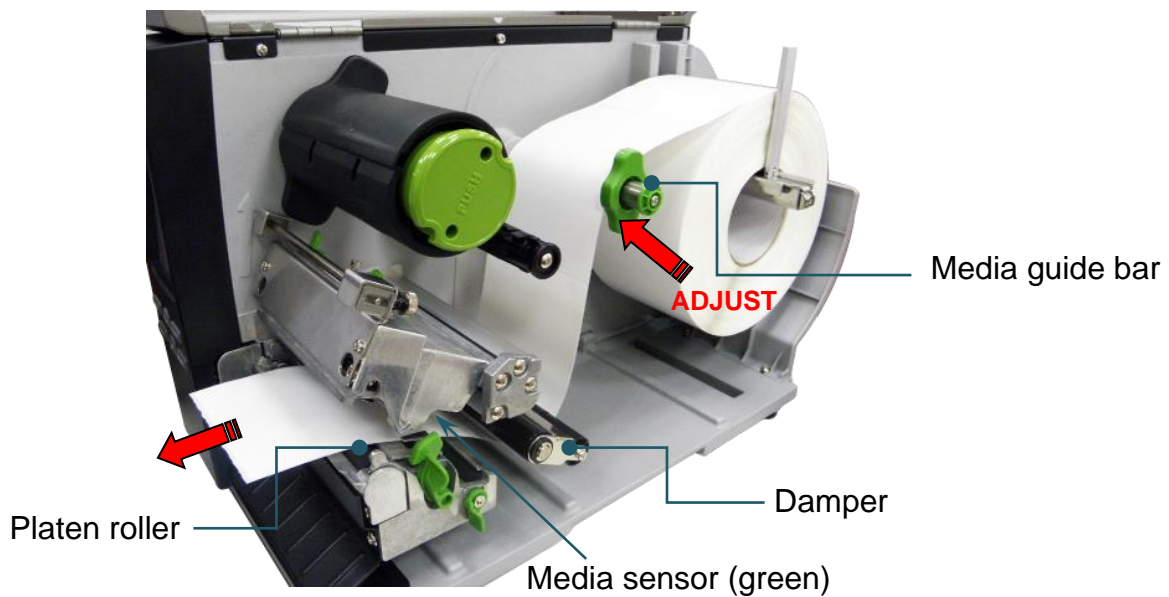

7. Unlock the media sensor to adjust. Align sensor (green triangle ▼) over label gap or black mark for proper sensing. After alignment re-lock sensor.

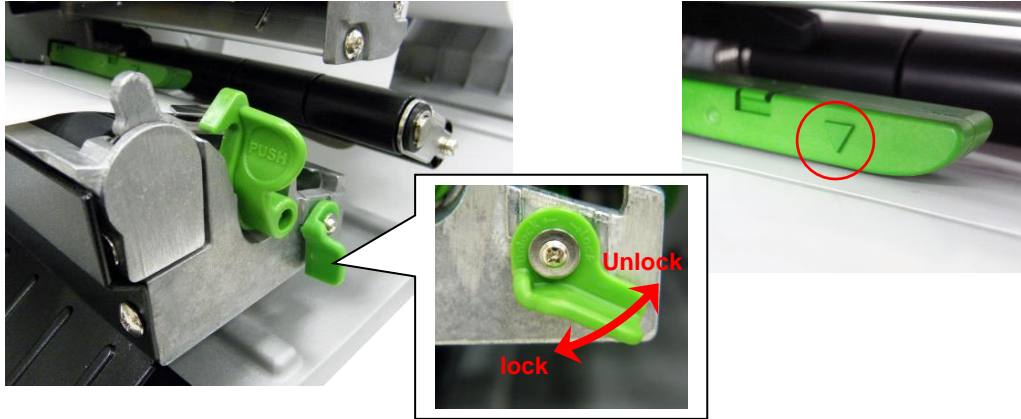

8. Adjust the label guides to fit the width of the media.

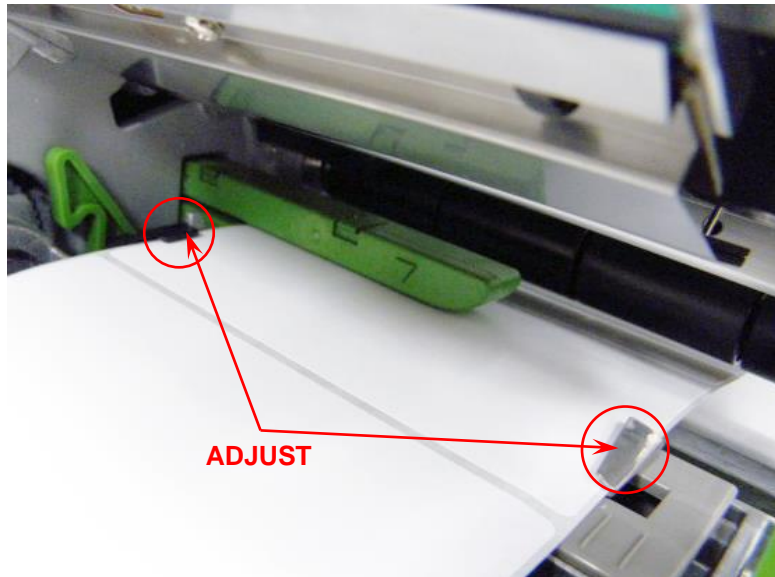

9. Close the print head mechanism and make sure the latches are engaged securely.

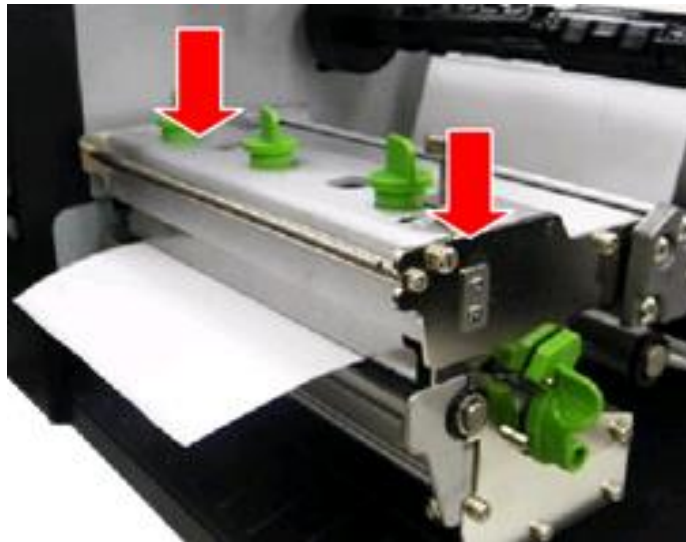

Media Routing

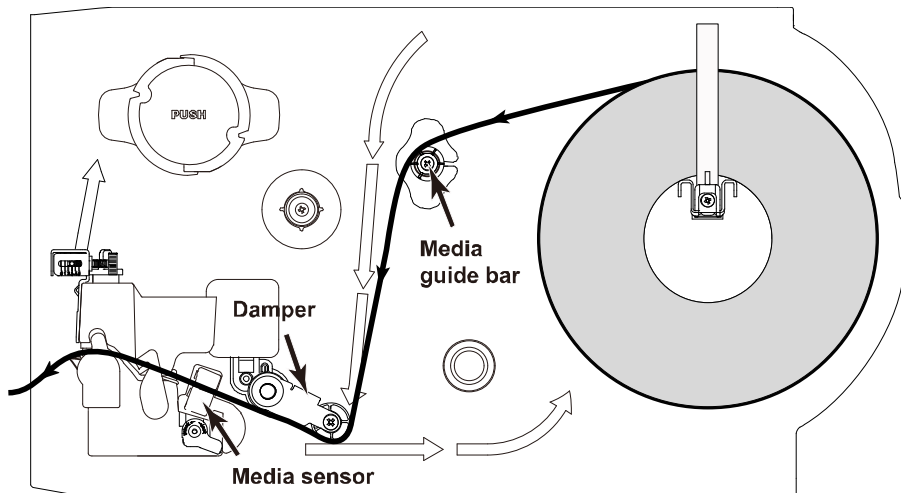

Media calibration is required when changing gap and black mark sensor type.

Loading fan fold media

1. Open the printer right side cover. Push the printhead release lever to open the mechanism.
2. Insert the fan-fold media through the rear or bottom external label entrance chute.
3. Pull fan-fold label leading edge forward over the media guide bar, under damper, through media sensor and place the media leading edge onto the platen roller.
4. Adjust the media sensor.
5. Adjust the label guides by sliding to fit the media width.
6. Close the print head mechanism. Make sure the latches are engaged securely.

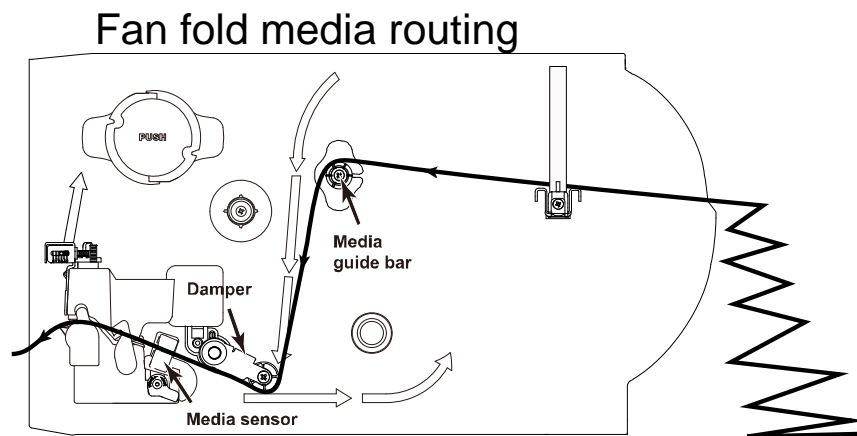

Loading media in peel mode

1. Open printer cover.
2. Open print head release lever and pull approximately two feet of label through the front of the printer.
3. Press down on the peel-off release lever to free the roller.

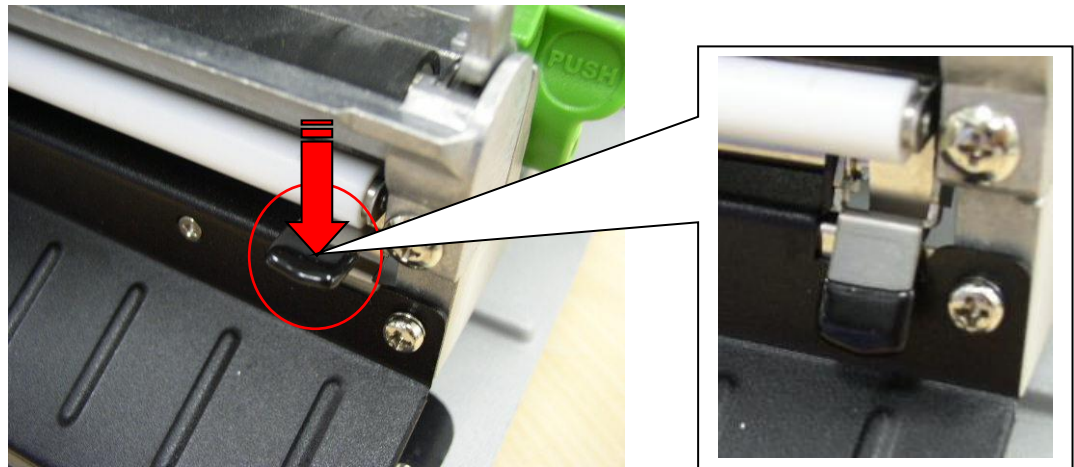

4. Feed the label between peel-off roller and platen roller.

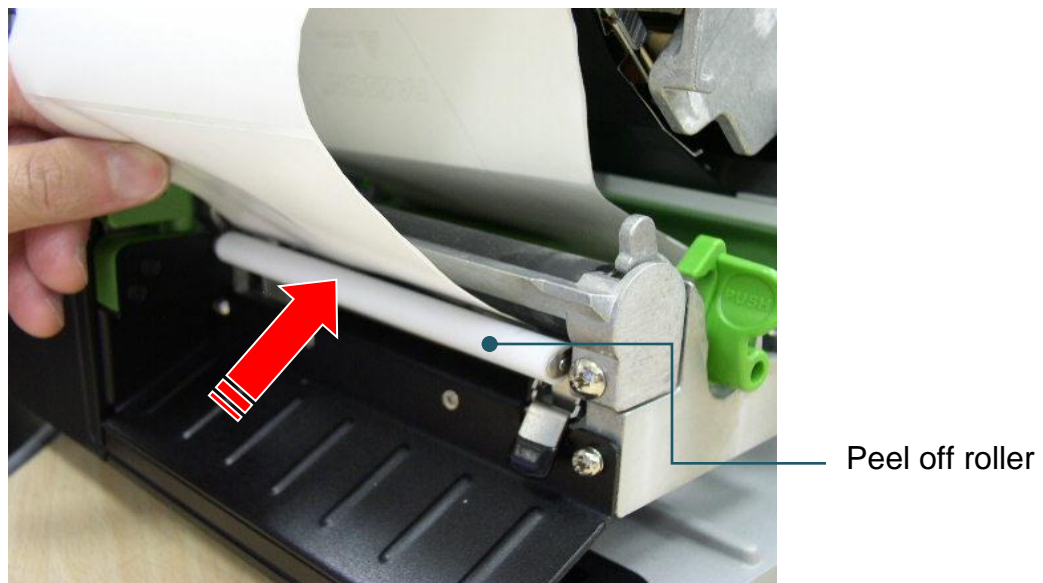

5. Feed label through mechanism.



6. Wrap the label onto the internal rewind spindle and turn the spindle counter-clockwise 3 to 5 turns until the slack is removed and properly stretched.

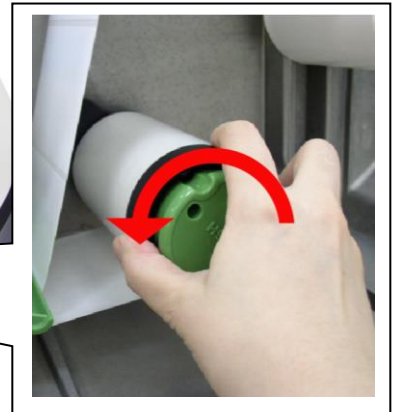
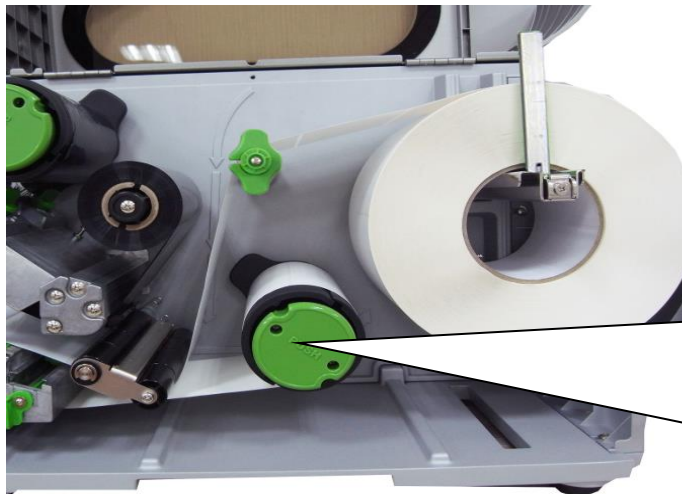

7. Lift up the peel-off roller release lever and close the print head mechanism. Move the peel-off sensor toward the paper exit chute.

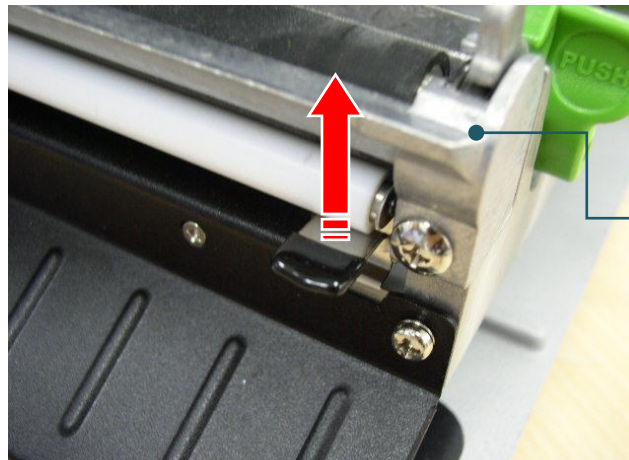

Close print head mechanism

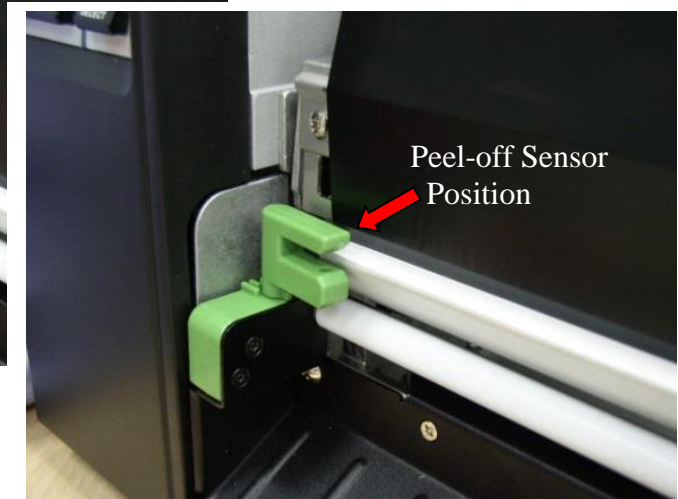

8. Label peeling will automatically start. Press the FEED button to test



Adjusting print head pressure

1. Pressure adjustment knobs:

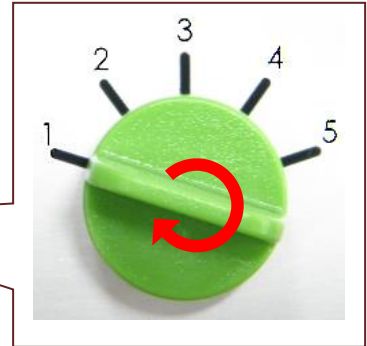
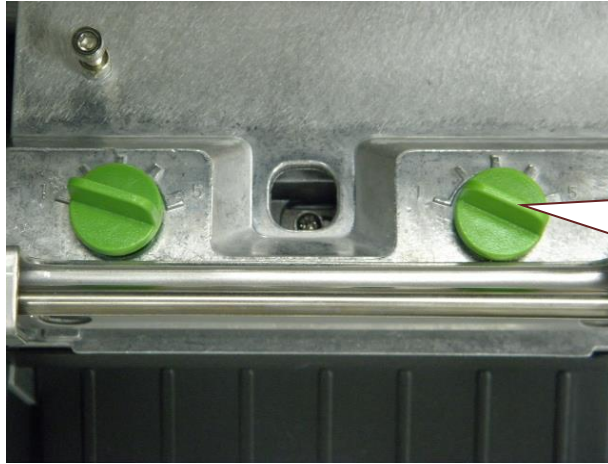

The print head pressure adjustment knob has 5 levels of adjustment. Because the printer's paper alignment is to the left side of mechanism, different media widths require different pressure to print correctly. Therefore, you may need to adjust the pressure knob to get your best print quality. For example, if the label width is 4", adjust both print head pressure adjustment knobs to the same level. If the label is less than 2" wide, increase the left side print head pressure by rotating the adjustment knob clockwise and decrease the right side pressure by rotating the adjustment knob counter-clockwise to level 1.

Print head burn line adjustment:

1. Burn line adjustment screws:

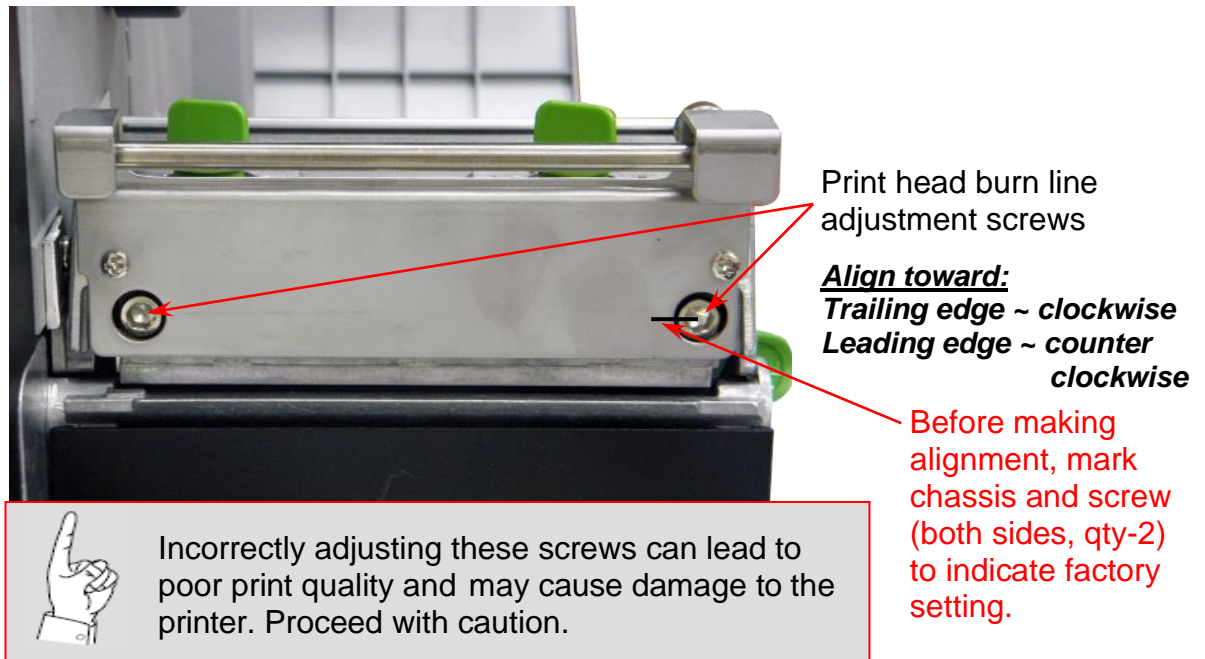

Before proceeding with burn line adjustment; verify print density, print head pressure adjustment, or z-axis alignments are properly adjusted. As a reference mark the chassis and screw(s) to indicate the factory setting, should it need to be restored.

The print head burn line adjustment screws are used to fine tune the print quality for different thickness of media. Turning the screws adjusts the print head burn line forward or backward as it relates to the platen roller. The print head burn line default is set for general purpose printing media (plain paper and paper thickness less than 0.008 inch).

Poor print quality when using paper thicker than 0.008 inch may be due to the print head burn line not being at the optimized position. To improve the print quality, increase the head pressure or adjust the screws counter-clockwise to move print head burn line toward the paper leading edge then print again. Adjusting the screws clockwise will move the burn line toward the trailing edge. Continue to adjust the burn line position and test print as necessary until the printout image is present and discernable with good print quality.

Ribbon flow adjustment (wrinkle removal):

Ribbon wrinkle is related to the media thickness, print head pressure balance, ribbon film characteristics, print darkness setting...etc. Press the FEED button several times to feed labels and potentially eliminate the noted ribbon wrinkle. Should feeding the labels not correct the problem, follow the below procedure:

1. Use the print head adjustment knob(s) to correct missing print caused by ribbon wrinkle. Adjustment knob; Clockwise direction will increase the print head pressure. Counter Clockwise adjustment can decrease the print head pressure.

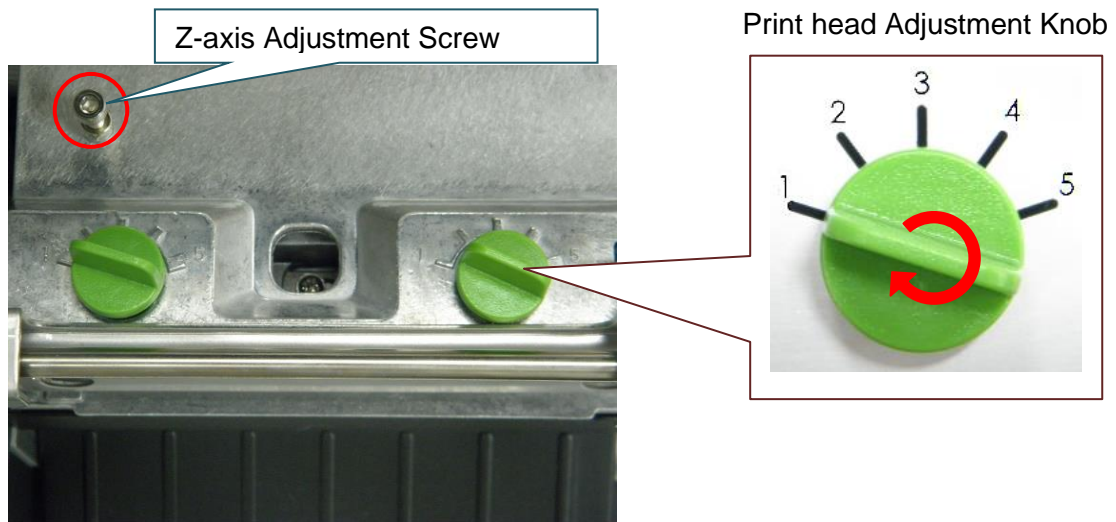

2. If the wrinkle on the printed label starts from the lower left side to upper right side, follow this adjustment procedure:



- Decrease the right print head pressure adjustment knob setting 1 increment. If the right print head adjustment knob setting was previously set to index 1 (the lowest pressure index), increase the left side print head pressure by one increment. Print the label again to check if wrinkle is gone.

NOTE: when the left print head adjustment knob setting was previously set to 5 (the highest pressure index) the wrinkle can't be avoided, rotate both knobs back to setting 1, then rotate the Z-axis mechanism adjustment Screw clockwise for a few degrees. Print the label again to check if wrinkle is gone. If not, continue with Z-axis alignment.

Z-axis Alignment:

- Turn the Z-axis mechanism adjustment screw clockwise until you feel contact with the mechanism. Print the label again to check if wrinkle is gone.
- If the wrinkle is still there, turn the Z-axis mechanism adjustment screw clockwise about 1/4 turn. Print the label again to check if wrinkle is gone. If not, keep repeating this step until the wrinkle is corrected. If the wrinkle direction changes from “/” to “\” by adjusting the Z-axis mechanism adjustment screw, turn the Z axis mechanism adjustment screw counter clockwise to avoid the wrinkle.

3. If the wrinkle on the printed label starts from the lower right side to upper left side, following this adjustment procedure:



- Decrease the Left print head pressure adjustment knob setting 1 increment. Print the label again to check if wrinkle is gone. If not, repeat this process until the ribbon wrinkle is eliminated.
- If the left side print head adjustment knob has been set to index 1 (the lowest index), increase the right print head pressure knob by one increment. Print the label again to check if wrinkle is gone.

Control Panel

LCD Menu

1. Enter the main Menu by Keys:
 - Press the “MENU” button, then press the “SELECT” button to enter the main menu
2. Enter the main Menu by touch display:
 - Tap the “Menu” icon on LCD to enter the main menu

Main Menu Overview

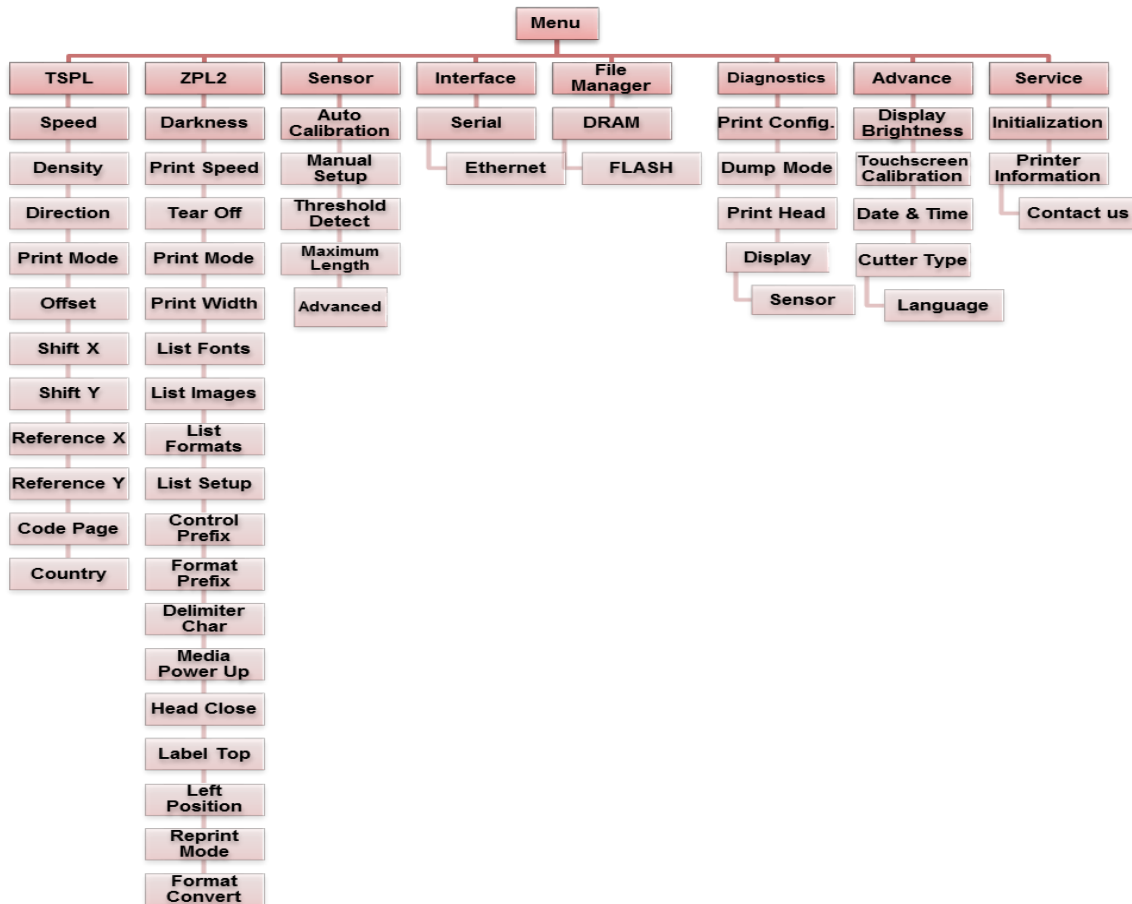

TSPL2

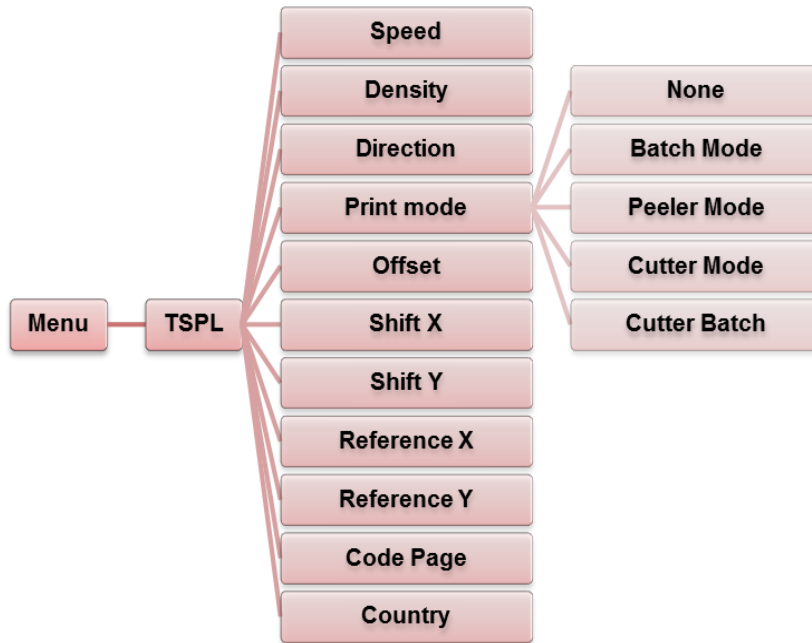

Item	Description	Default
Speed	Use this item to setup print speed. Each increase or decrease is 1 inch per second. Available setting is from 4 to 12.	6
Density	Use this option to setup printing darkness. The available setting is from 0 to 15, and the step is 1. You may need to adjust your density based on selected media.	8
Direction	<p>The direction setting value is either 1 or 0. Use this item to setup the printout direction.</p>	0

Print mode	This item is used to set the print mode. There are 5 modes as listed below:	Batch Mode										
	<table border="1"> <thead> <tr> <th>Printer Mode</th> <th>Description</th> </tr> </thead> <tbody> <tr> <td>None</td> <td>Next label top of form is aligned to the print head burn line location. (Tear Off Mode)</td> </tr> <tr> <td>Batch Mode</td> <td>Once image is printed completely, label gap/black mark will be fed to the tear plate location for tear away.</td> </tr> <tr> <td>Peeler Mode</td> <td>Enable the label peel off mode.</td> </tr> <tr> <td>Cutter Mode</td> <td>Enable the label cutter mode.</td> </tr> <tr> <td>Cutter Batch</td> <td>Cut the label once at the end of the print job.</td> </tr> </tbody> </table>		Printer Mode	Description	None	Next label top of form is aligned to the print head burn line location. (Tear Off Mode)	Batch Mode	Once image is printed completely, label gap/black mark will be fed to the tear plate location for tear away.	Peeler Mode	Enable the label peel off mode.	Cutter Mode	Enable the label cutter mode.
Printer Mode	Description											
None	Next label top of form is aligned to the print head burn line location. (Tear Off Mode)											
Batch Mode	Once image is printed completely, label gap/black mark will be fed to the tear plate location for tear away.											
Peeler Mode	Enable the label peel off mode.											
Cutter Mode	Enable the label cutter mode.											
Cutter Batch	Cut the label once at the end of the print job.											
Offset	This item is used to fine tune media stop location. Available setting value is from "+" to "-" or "0" to "9".	+000										
Shift X	This item is used to fine tune print position. Available setting value is from "+" to "-" or "0" to "9".	+000										
Shift Y		+000										
Reference X	This item is used to set the origin of printer coordinate system, horizontally and vertically. Available setting value is from "0" to "9".	000										
Reference Y		000										
Code page	Use this item to set the code page of international character set.	850										
Country	Use this option to set the country code.	001										

Note: If printing from enclosed software/driver, it will take precedence and overwrite the settings entered from the panel.

ZPL2

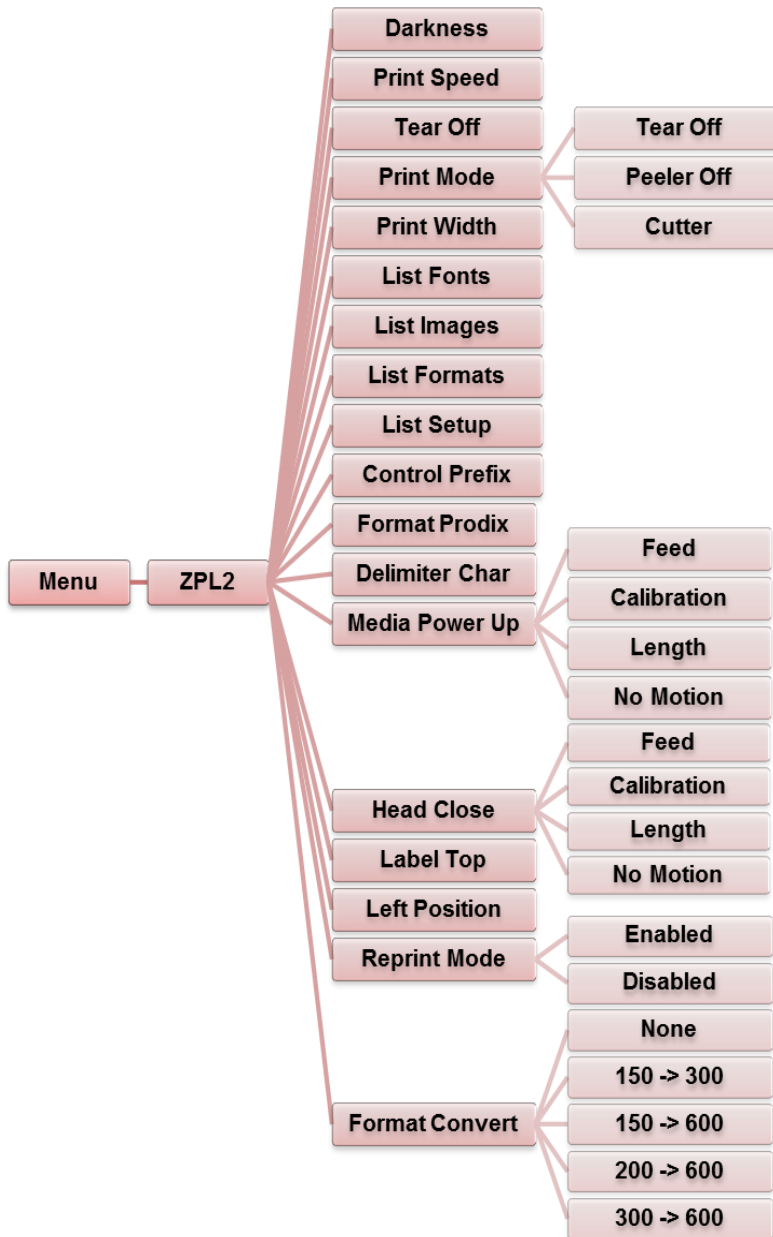

Item	Description	Default								
Darkness	Use this item to setup printing darkness. The available setting is from 0 to 30, incremented by 1. You may need to adjust your density based on selected media.	16								
Print Speed	Use this item to setup print speed. Each increase or decrease is 1 ips. Available setting is from 1 to 6.	N/A								
Tear Off	This item is used to fine tune media stop location. Available setting value is from "+" to "-" or "0" to "120" dots.	+000								
Print mode	<p>This item is used to set the print mode. There are 3 modes as listed below:</p> <table border="1"> <thead> <tr> <th>Printer Mode</th> <th>Description</th> </tr> </thead> <tbody> <tr> <td>Tear Off</td> <td>Next label top of form is aligned to the print head burn line location.</td> </tr> <tr> <td>Peeler Off</td> <td>Enable the label peel off mode.</td> </tr> <tr> <td>Cutter</td> <td>Enable the label cutter mode</td> </tr> </tbody> </table>	Printer Mode	Description	Tear Off	Next label top of form is aligned to the print head burn line location.	Peeler Off	Enable the label peel off mode.	Cutter	Enable the label cutter mode	Tear Off
Printer Mode	Description									
Tear Off	Next label top of form is aligned to the print head burn line location.									
Peeler Off	Enable the label peel off mode.									
Cutter	Enable the label cutter mode									
Print Width	This item is used to set print width. The available value is from "0" to "832" dots.	812 dots								
List Fonts	This feature is used to print current printer available font lists. The fonts stored in the printer's DRAM, Flash or optional memory card.	N/A								
List Images	This feature is used to print current printer available image lists. The images stored in the printer's DRAM, Flash or optional memory card.	N/A								
List Formats	This feature is used to print current printer available format lists. The formats stored in the printer's DRAM, Flash or optional memory card.	N/A								
List Setup	This feature is used to print current printer configuration on the label.	N/A								
Control Prefix	This feature is used to set control prefix character.	N/A								
Format Prefix	This feature is used to set format prefix character.	N/A								
Delimiter Char	This feature is used to set delimiter character.	N/A								

Media Power Up	This option is used to set the media action when you turn on the printer.	No Motion										
	<table border="1"> <thead> <tr> <th>Selections</th> <th>Description</th> </tr> </thead> <tbody> <tr> <td>Feed</td> <td>Printer will advance one label</td> </tr> <tr> <td>Calibration</td> <td>Printer will calibrate the sensor levels, determine length and feed label</td> </tr> <tr> <td>Length</td> <td>Printer will determine length and feed label</td> </tr> <tr> <td>No Motion</td> <td>Printer will not move media</td> </tr> </tbody> </table>		Selections	Description	Feed	Printer will advance one label	Calibration	Printer will calibrate the sensor levels, determine length and feed label	Length	Printer will determine length and feed label	No Motion	Printer will not move media
	Selections		Description									
	Feed		Printer will advance one label									
	Calibration		Printer will calibrate the sensor levels, determine length and feed label									
Length	Printer will determine length and feed label											
No Motion	Printer will not move media											
Head Close	This option is used to set the media action when you close the print head mechanism.	No Motion										
	<table border="1"> <thead> <tr> <th>Selections</th> <th>Description</th> </tr> </thead> <tbody> <tr> <td>Feed</td> <td>Printer will advance one label</td> </tr> <tr> <td>Calibration</td> <td>Printer will calibrate the sensor levels, determine length and feed label</td> </tr> <tr> <td>Length</td> <td>Printer will determine print length and feed label</td> </tr> <tr> <td>No Motion</td> <td>Printer will not move media</td> </tr> </tbody> </table>		Selections	Description	Feed	Printer will advance one label	Calibration	Printer will calibrate the sensor levels, determine length and feed label	Length	Printer will determine print length and feed label	No Motion	Printer will not move media
	Selections		Description									
	Feed		Printer will advance one label									
	Calibration		Printer will calibrate the sensor levels, determine length and feed label									
Length	Printer will determine print length and feed label											
No Motion	Printer will not move media											
Label Top	This option is used to adjust print position vertically on the label. The range is -120 to +120 dots.	0										
Left Position	This option is used to adjust print position horizontally on the label. The range is -9999 to +9999 dots.	+0000										
Reprint Mode	When reprint mode is enabled, you can reprint the last label printed by pressing the UP  button on the control panel.	Disabled										
Format Convert	Selects the bitmap scaling factor. The first number is the original dots per inch (dpi) value; the second, the dpi to which you would like to scale.	None										

Note: If printing from enclosed software/driver, it will take precedence and overwrite the settings entered from the panel.

Sensor

This option is used to calibrate the selected sensor. We recommend sensor calibration when changing media and before printing.

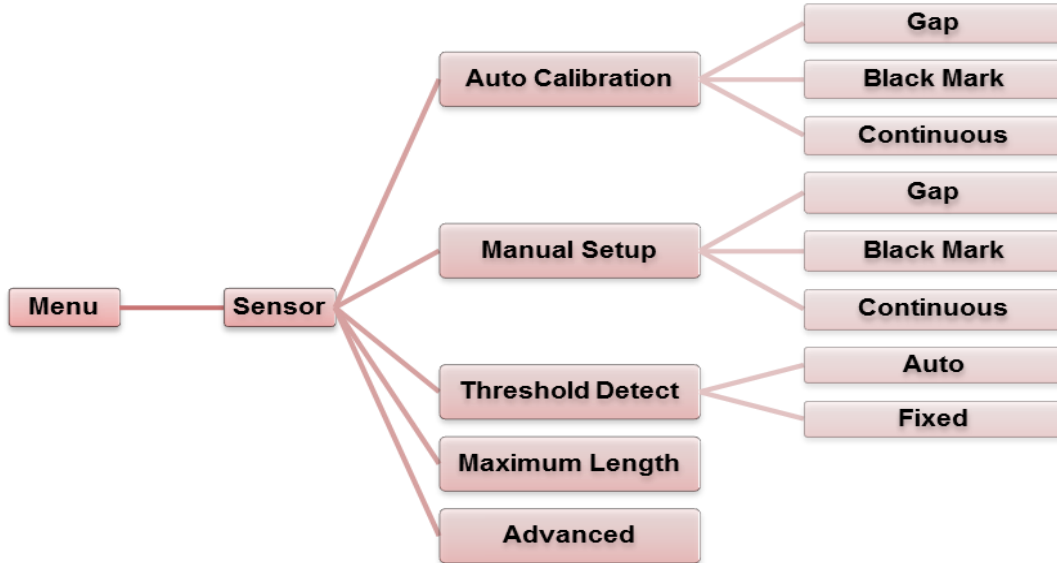

Item	Description	Default
Auto Calibration	This option is used to set the media sensor type and calibrate the selected sensor automatically. Printer will feed 2 to 3 gap labels to calibrate the sensor sensitivity automatically.	N/A
Manual setup	In case “Automatic” does not apply to the media type, use “Manual” function to set the paper length and gap/b line size. Then scan the backing/mark to calibrate the sensor sensitivity.	N/A
Threshold Detect	This option is used to set sensor sensitivity in fixed or auto mode.	Auto
Maximum Length	This option is used to set the maximum length for label calibration.	9.9 inch
Advanced	This function can set the minimum paper length and maximum gap/b line length for “auto-calibrate” sensor sensitivity.	N/A

Interface

This option is used to set the printer interface settings.



Serial

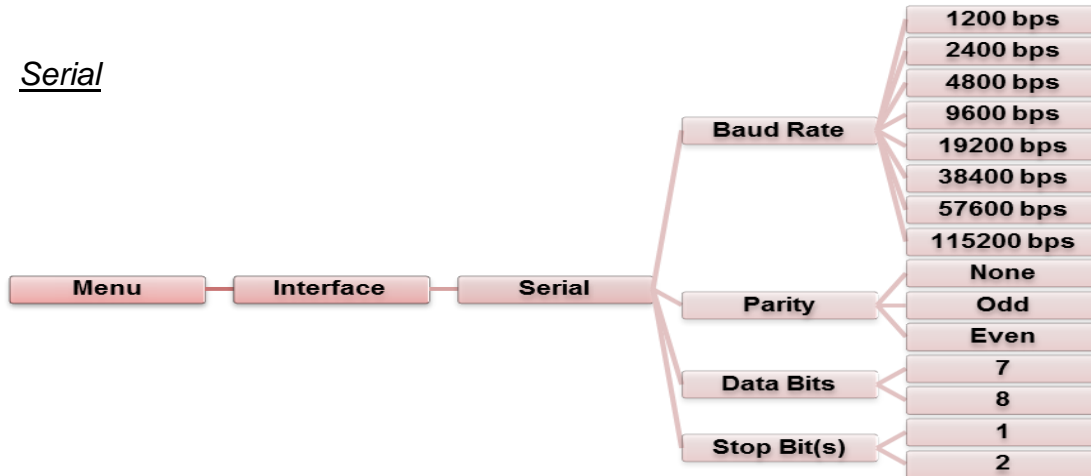

Item	Description	Default
Baud Rate	This item is used to set the RS-232 baud rate.	9600
Parity	This item is used to set the RS-232 parity.	None
Data Bits	This item is used to set the RS-232 Data Bits.	8
Stop Bit(s)	This item is used to set the RS-232 Stop Bits.	1

Ethernet

Use this menu option is to configure the internal Ethernet, verify status, and reset the module.



Item	Description	Default
Status	Use this menu to check the Ethernet IP address and MAC setting status.	N/A
DHCP	This item is used to turn ON or OFF the DHCP (Dynamic Host Configuration Protocol) network protocol.	N/A
Static IP	Use this menu to set the printer's IP address, subnet mask and gateway.	N/A

File Manager

This feature is used to check the printer's available memory and file list.



Item	Description
DRAM	Use this menu to show, delete and run (.BAS) files saved in the printer DRAM memory.
FLASH	Use this menu to show, delete and run (.BAS) files saved in the printer Flash memory.

Diagnostics

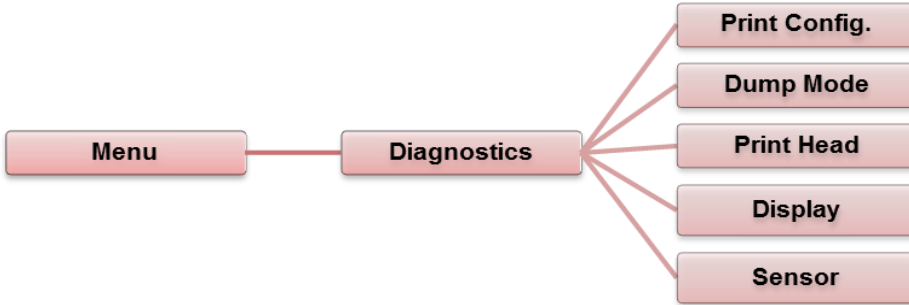

Print Configuration

This feature prints the current printer configuration.

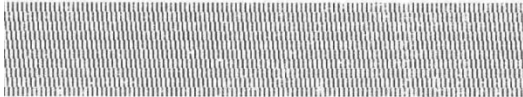

Self-test printout	
<pre> ----- SYSTEM INFORMATION ----- MODEL: XXXXXX FIRMWARE: X.XX CHECKSUM: XXXXXXXX S/N: XXXXXXXXXXXX TCF: NO DATE: 1970/01/01 TIME: 00:04:18 NON-RESET: 110 m (TPH) RESET: 110 m (TPH) NON-RESET: 0 (CUT) RESET: 0 (CUT) ----- PRINTING SETTING ----- SPEED: 5 IPS DENSITY: 8.0 WIDTH: 4.00 INCH HEIGHT: 4.00 INCH GAP: 0.00 INCH INTENSION: 5 CODEPAGE: 850 COUNTRY: 001 ----- </pre>	<ul style="list-style-type: none"> Model name F/W version Firmware checksum Printer S/N Configuration file System date System time Printed mileage (meter) Cutting counter Print speed (inch/sec) Print darkness Label size (inch) Gap distance (inch) Gap/black mark sensor intension Code page Country code

<pre> ----- Z SETTING ----- DARKNESS: 16.0 SPEED: 4 IPS WIDTH: 4.00 INCH TILDE: 7EH (~) CARET: 5EH (^) DELIMITER: 2CH (,) POWER UP: NO MOTION HEAD CLOSE: NO MOTION ----- </pre>	<p>ZPL setting information</p> <ul style="list-style-type: none"> Print darkness Print speed (inch/sec) Label size Control prefix Format prefix Delimiter prefix Printer power up motion Printer head close motion <p>Note: ZPL is a Zebra® language emulation.</p>
<pre> ----- RS232 SETTING ----- BAUD: 9600 PARITY: NONE DATA BIT: 8 STOP BIT: 1 ----- </pre>	<p>RS232 serial port configuration</p>
<pre> ----- DRAM FILE (0 FILES) ----- PHYSICAL XXXX KBYTES AVAILABLE XXXX KBYTES ----- FLASH FILE (0 FILES) ----- PHYSICAL XXXX KBYTES AVAILABLE XXXX KBYTES -----  </pre>	<p>Numbers of download files Total & available memory space</p> <p>Print head check pattern</p>

Note: Printing the configuration page requires 4" wide paper.

Dump Mode

Captures the data from the communications port and prints out the data received by the printer. In the dump mode, all characters will be printed in 2 columns. The left side characters are received from your system and right side data are the corresponding hexadecimal value of the characters. It allows users or engineers to verify and debug the program. **Note: Printing a dump requires 4" wide paper.**

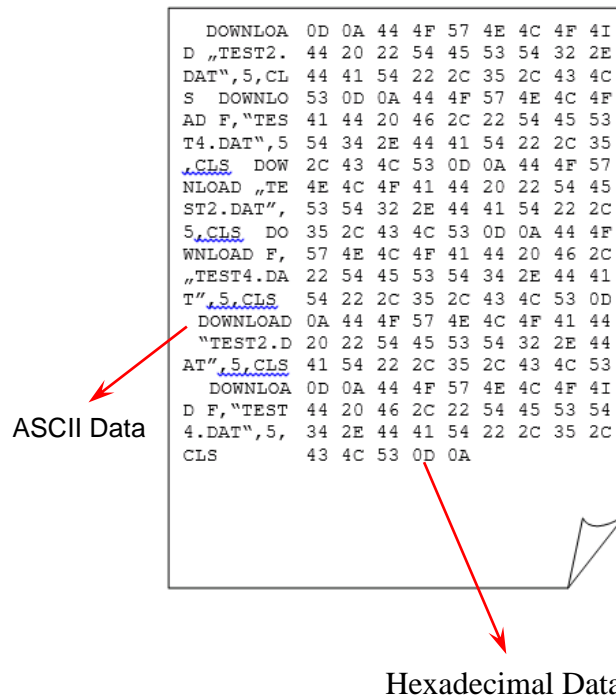

Print Head

This feature verifies the head temperature, resistance and missing dots.



Display

This feature verifies the display.



Sensor

This feature verifies the sensor setting.

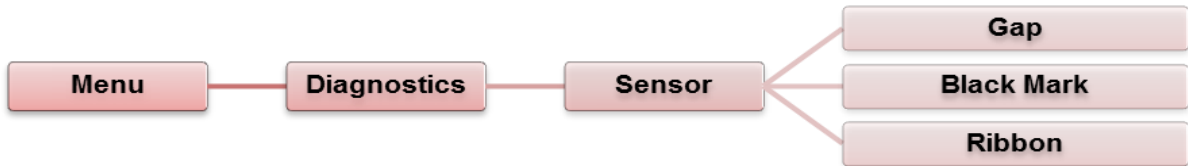

Advanced

This feature is used to set the printer advanced settings.

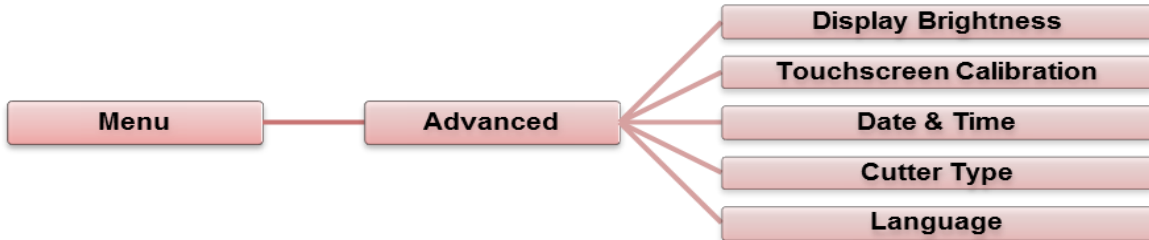

Item	Description
Display Brightness	This item is used to adjust the brightness for display.
Touchscreen Calibration	This item is used to calibrate the touchscreen.
Date & Time	This item is used to setup the display date and time.
Cutter Type	This item is used to set the cutter type.
Language	This item is used to setup the display language.

Service

This feature is used to restore printer settings to factory defaults.



Item	Description
Initialization	This feature is used to restore printer default settings.
Printer Information	This feature is used verify the printer serial number, printed mileage(m), labels(pcs.) and cutting counter.

PAL™ Print and Program Overview

Printers featuring PAL™ Print and Program utility can be used in several ways in any given environment. This section describes 3 common ways this advanced capability is used. For help and assistance determining the best way to use this utility in your situation, please consult your sales representative.

PALSECURE ON DEMAND™

Also available is *PALSECURE ON DEMAND™ Label Reprints*: allows healthcare professionals to print secure data on labels and wristbands anywhere in the hospital – no network connection required. This solution provides label printing on demand, using automatic encryption of patient data and decryption only with an authorized printer/scanner combination. Please enquire with your sales representative for more information.

Traditional Printing

This environment represents the most common use of printers. Generally, a single print job (PAL™ print sequences) generates a single label. In this role the PAL™ Print and Program interpreter accepts the print job, performs the required operator processing and prints the; label, tag, or ticket. Using a Windows driver in conjunction with a Windows application program is a typical way to print in this environment. Alternatively, PAL™ print sequences may also be generated by any host application written to take advantage of this powerful language. When a PAL™ capable printer is used this way, no special “PAL™ program” must be loaded on the printer. Print sequences generated by a Windows driver or host program are simply sent to the printer resulting in print output just like traditional printers.

Legacy Data Stream Interpretation

PAL™ Print and Program capable printers uniquely address applications where upgrading to modern cost effective technology is desired. Often cost-prohibitive software reprogramming to change a data stream prevents an organization from moving to new printing technologies.

Using a PAL™ Print and Program capable printer solves this problem. In this case a PAL™ program is written which interprets a data stream normally sent to the legacy device being replaced. This program is stored on the printer and is automatically executed each time the printer is powered on. This program is able to produce a new label format based on this legacy data. Even though the host computer is sending the exact same legacy data to the printer, the label format can be completely different. For example, the new format may include bar codes, scaled and/or rotated fonts, lines, logo's etc. Even though the legacy device being replaced does not support these print abilities, the new label format can.

For example, text only outputs such as produced by a dot-matrix printer or card embosser may now be presented in a more functional format. Information in the data stream can be reformatted into any size font in any rotation, or even printed as bar code. This example demonstrates how PAL™ Print and Program capable printers can replace a legacy print device with no host software changes required.

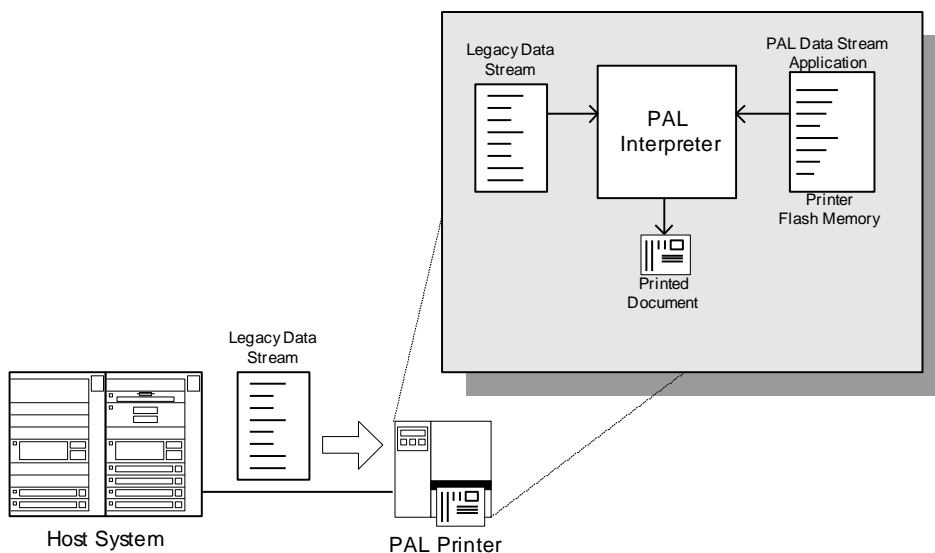

Standalone/Downtime Applications

PAL™ Print and Program capable printers may be programmed to operate independent of a PC/host connection. This standalone ability may be used in cases where no PC/host connection is needed or as a fail-safe backup when the PC/host or network is unavailable. The Standalone Application program is stored in the printer memory and can accept input from a PS/2 keyboard, bar code scanner, or other serial device such as an electronic scale. These programs may use the printer's LCD to prompt for user input and may also include databases. Unlike other bar code printers that allow basic static forms to be loaded in the printer, PAL™ Print and Program capable printers provide advanced capabilities.

Examples of these advanced capabilities are:

- ❑ Ability to operate on line from host or off line in stand-alone mode
- ❑ Ability to range check user input
- ❑ Ability to combine data from multiple fields into a single bar code
- ❑ Ability to access database stored in printer
- ❑ Ability to perform math calculations (addition, subtraction, multiplication, division, etc.)
- ❑ Ability to perform logical calculations (equal to, less than, greater than, etc.)

Shown below is an example where a stand-alone PAL™ application and database is stored in the printer. Operator input combined with internal database information is used to create a label. For example, this application could request a part number and physical dimensions of a particular part by prompting for this information on the printer LCD. After the operator inputs the requested information on the PS/2 keyboard, the printer could calculate the volume, and then based on the part number, lookup the part description in a database to produce a label.

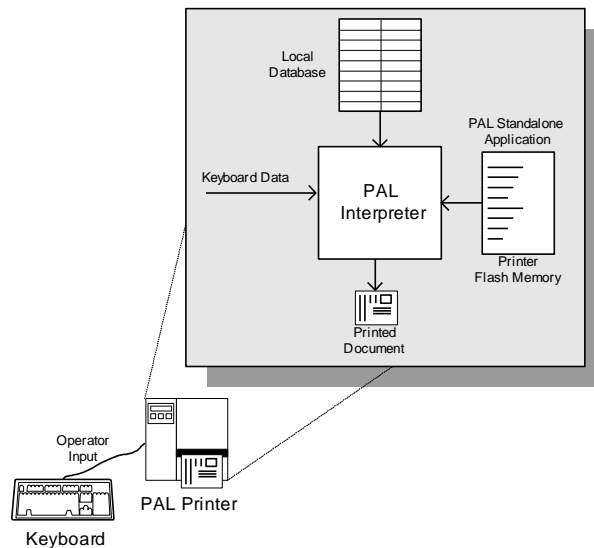

Diagnostic Tool

The Diagnostic Utility is a toolbox that allows users to explore the printer's settings and status; change printer settings; download graphics, fonts, and firmware; create printer bitmap fonts; and to send additional commands to the printer. Using this convenient tool, you can explore the printer status and settings and troubleshoot the printer.

Start Diagnostic Tool

1. Double click on the Diagnostic tool icon  `DiagTool.exe` to start the software.
2. There are four features (Printer Configuration, File Manager, Bitmap Font Manager, Command Tool) included in the Diagnostic utility.

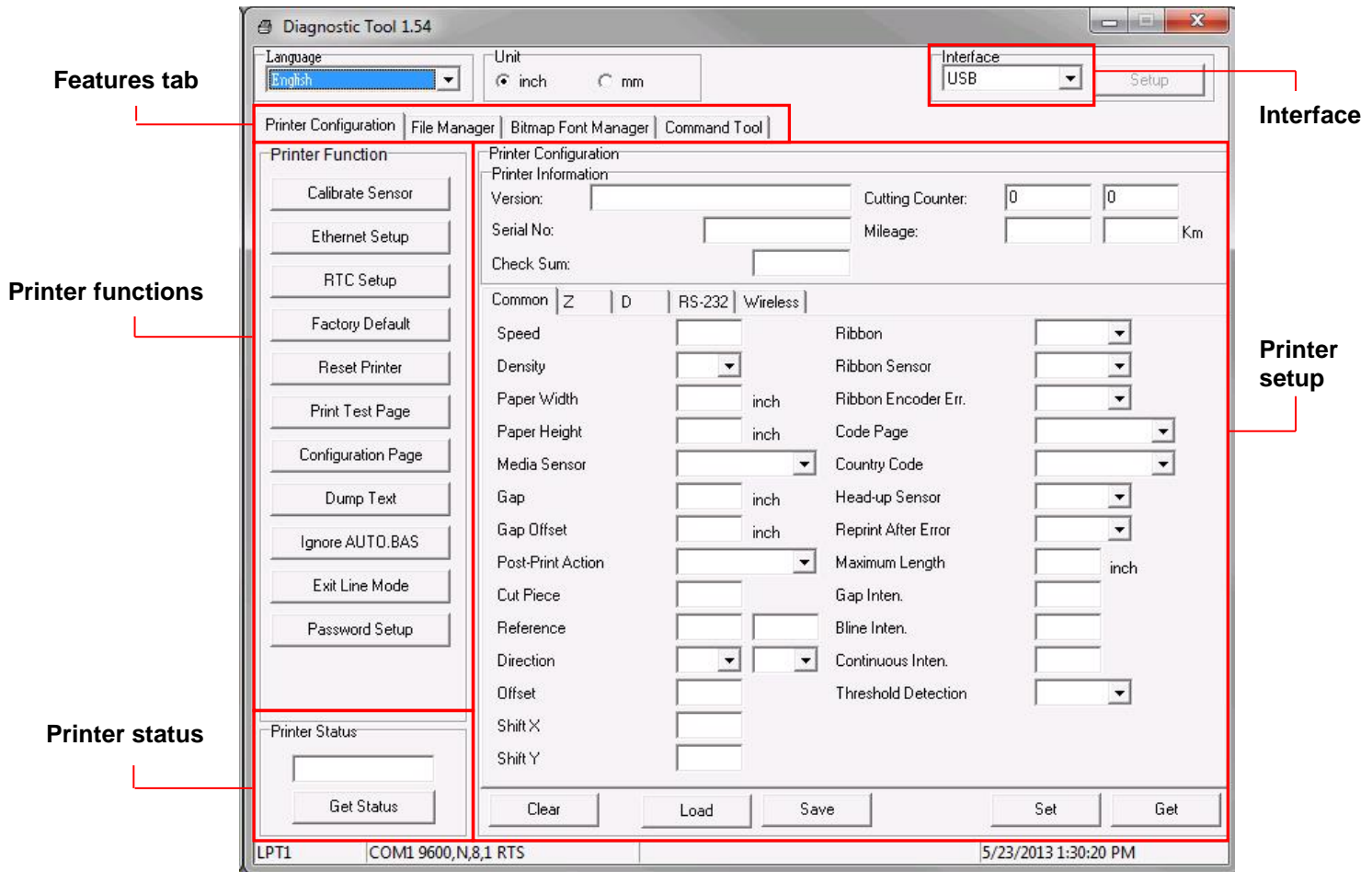

Printer Function (Calibrate sensor, Ethernet setup, RTC setup...)

1. Select the PC interface connected to the bar code printer.
2. Click the “Function” button for settings.
3. The detail functions in the Printer Function Group are listed as below.

Printer Function	Function	Description
Calibrate Sensor	Calibrate Sensor	Calibrate the sensor specified in the Printer Setup group media sensor field
Ethernet Setup	Ethernet Setup	Setup the IP address, subnet mask, gateway for the on board Ethernet
RTC Setup	RTC Setup	Synchronize printer Real Time Clock with PC
Factory Default	Factory Default	Initialize the printer and restore the settings to factory default.
Reset Printer	Reset Printer	Reboot printer
Print Test Page	Print Test Page	Print a test page
Configuration Page	Configuration Page	Print printer configuration
Dump Text	Dump Text	To activate the printer dump mode.
Ignore AUTO.BAS	Ignore AUTO.BAS	Ignore the downloaded AUTO.BAS program
Exit Line Mode	Exit Line Mode	Exit line mode.
Password Setup	Password Setup	Set the password to protect the settings



For more information about the Diagnostic Tool, please refer to the diagnostic utility quick start guide in the CD disk \ Diagnostic Utilities directory.

Setting Ethernet by Diagnostic Utility

The Diagnostic Utility is enclosed in the CD disk \Diagnostic Utilities directory. Users can use the Diagnostic Tool to setup the Ethernet by RS-232, USB and Ethernet interfaces. The following contents will instruct users how to configure the Ethernet by these three interfaces.

Using USB interface to setup Ethernet interface

1. Connect the USB cable between the computer and the printer.
2. Turn on the printer power.
3. Start the Diagnostic Utility by double clicking on the  `DiagTool.exe` icon.
4. The Diagnostic Utility default interface setting is USB. If the USB interface is connected to the printer, no other settings need to be changed in the interface field.

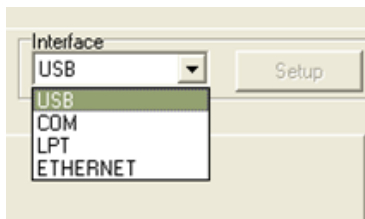

5. Click on the Printer Function “Ethernet Setup” button. DHCP is the default. Select “Static IP” to assign the IP address, subnet mask and gateway for the on board Ethernet.

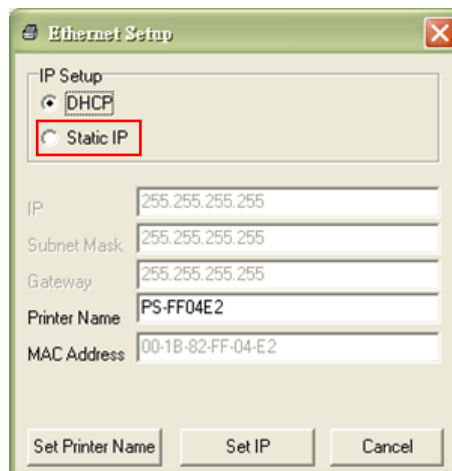
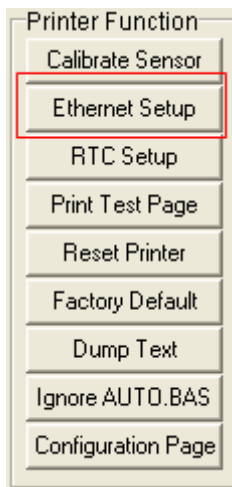

Using RS-232 interface to setup Ethernet interface

1. Connect the computer and the printer with a RS-232 cable.
2. Turn on the printer power.
3. Start the Diagnostic Utility by double clicking on the  `DiagTool.exe` icon.
4. Select “COM” as interface then click on the “Setup” button to select the serial port baud rate, parity check, data bits, stop bit and flow control parameters.

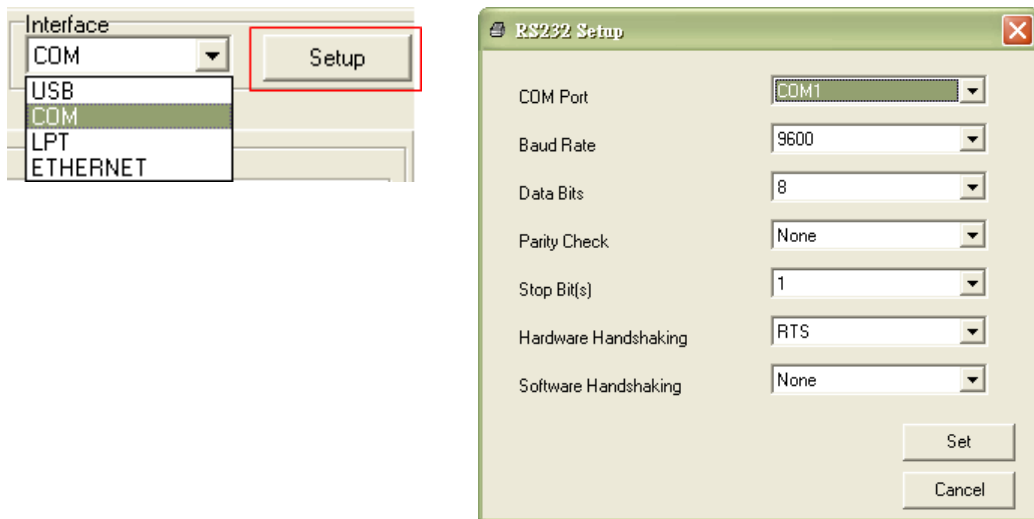

5. Click on the Printer Function “Ethernet Setup” button. DHCP is the default. Select “Static IP” to assign the IP address, subnet mask and gateway for the on board Ethernet.

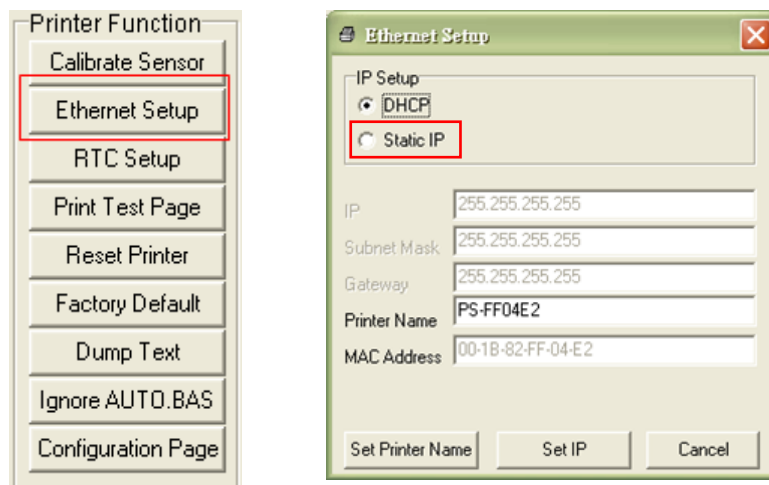

Using Ethernet interface to setup Ethernet interface

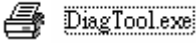
1. Connect the computer and the printer to the LAN.
2. Turn on the printer power.
3. Start the Diagnostic Utility by double clicking on the  icon.
4. Select “Ethernet” as the interface then click on the “Setup” button to setup the IP address, subnet mask and gateway for the on board Ethernet.

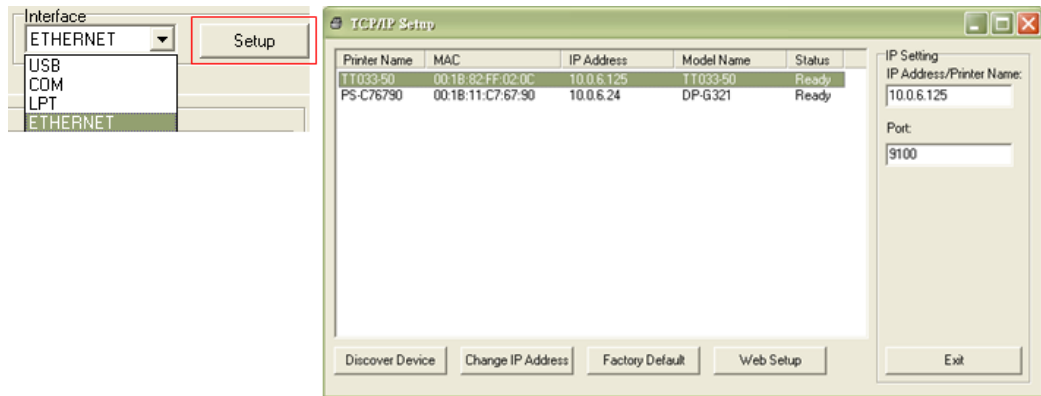

5. Click the “Discover Device” button to explore the printers that exist on the network.
6. Select the printer in the left side of listed printers, the correspondent IP address will be shown in the right side “IP address/Printer Name” field.
7. Click “Change IP Address” to configure the IP address obtained by DHCP or static.

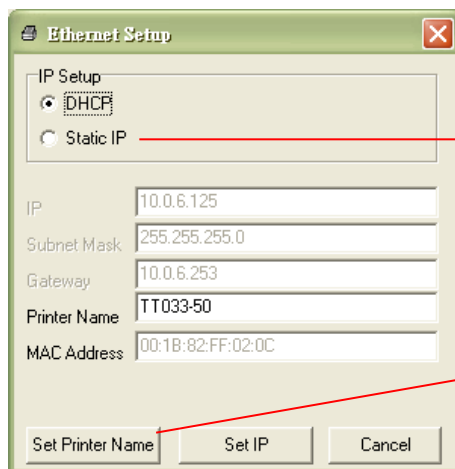

The default IP address is obtained by DHCP. To change the setting to static IP address, click “Static IP” radio button, then enter the IP address, subnet mask and gateway. Click “Set IP” button to save new IP address

Users can also change the “Printer Name” to another model name in this field. Click “Set Printer Name” to save new name.

8. Click “Exit” button to exit and go back to Diagnostic Tool main screen.

Factory Default button

This function will reset the IP address, subnet mask and gateway parameters obtained by DHCP and reset the printer name.

Web setup button

While using the Diagnostic Utility to setup the printer, you can also explore and configure the printer settings and status or update the firmware within the IE or Firefox web browser. This feature provides a user friendly setup interface and the capability of managing the printer remotely over a network.

Troubleshooting

Common Problems

The following guide lists the most common problems that may be encountered when operating this bar code printer. If the printer still does not function after all suggested solutions have been invoked, please contact the Customer Service Department of your purchased reseller or distributor for assistance.

Problem	Possible Cause	Recovery Procedure
Power indicator does not illuminate	<ul style="list-style-type: none"> * The power cord is not properly connected. 	<ul style="list-style-type: none"> * Plug the power cord in printer and outlet. * Switch the printer on.
Carriage Open	<ul style="list-style-type: none"> * The printer carriages are open. 	<ul style="list-style-type: none"> * Please close the print carriages.
Not Printing	<ul style="list-style-type: none"> * The external interface cable is not connected correctly. * The wireless or Bluetooth device is not correctly connected between host and printer. * The port specified in the Windows driver is not correct. 	<ul style="list-style-type: none"> * Re-connect interface cable or replace cable. * Please reset the wireless device setting. * Select the correct printer port in the driver. * Clean the printhead. * Print head's harness connector(s) are not properly connected. Turn off the printer and reconnect. * Check your program if there is a command PRINT at the end of the file. There should be a CRLF at the end of each command line.
No print on the label	<ul style="list-style-type: none"> * Label or ribbon is incorrectly installed. * Using the wrong type of paper or ribbon. 	<ul style="list-style-type: none"> * Follow the instructions in loading the media and ribbon. * Ribbon and media are not compatible. * Verify the ribbon-inked side. * The print density setting is incorrect.
No Ribbon	<ul style="list-style-type: none"> * Running out of ribbon. * The ribbon is installed incorrectly. 	<ul style="list-style-type: none"> * Supply a new ribbon roll. * Please refer to the steps in user's manual to reinstall the ribbon.

Problem	Possible Cause	Recovery Procedure
No Paper	<ul style="list-style-type: none"> * Running out of label. * The label is installed incorrectly. * Gap/black mark sensor is not calibrated. 	<ul style="list-style-type: none"> * Supply a new label roll. * Please refer to the steps in user's manual to reinstall the label roll. * Calibrate the gap/black mark sensor.
Paper Jam	<ul style="list-style-type: none"> * Gap/black mark sensor is not set properly. * Make sure label size is set properly. * Labels may be stuck inside the printer mechanism. 	<ul style="list-style-type: none"> * Calibrate the media sensor. * Set media size correctly. * Remove the stuck label inside the printer mechanism.
Take Label	<ul style="list-style-type: none"> * Peel function is enabled. 	<ul style="list-style-type: none"> * If the peeler module is installed, please remove the label. * If there is no peeler module in front of the printer, please switch off the printer and install it. * Check if the connector is plugging correctly.
Cannot download a file to memory (FLASH / DRAM/CARD)	<ul style="list-style-type: none"> * The space in memory is full. 	<ul style="list-style-type: none"> * Delete unused files in the memory.
Cannot access SD card	<ul style="list-style-type: none"> * SD card is damaged. * SD card doesn't insert correctly. * Use the non-approved SD card manufacturer. 	<ul style="list-style-type: none"> * Use the supported capacity SD card. * Insert the SD card again. * The supported SD card spec and the approved SD card manufacturer.
Poor Print Quality	<ul style="list-style-type: none"> * Ribbon and media is loaded incorrectly * Dust or adhesive accumulation on the print head. * Print density is not set properly. * Printhead element is damaged. * Ribbon and media are incompatible. * The printhead pressure is not set properly. 	<ul style="list-style-type: none"> * Reload the supply. * Clean the print head. * Clean the platen roller. * Adjust the print density and print speed. * Run printer self-test and check the print head test pattern if there is dot missing in the pattern. * Change proper ribbon or proper label media. * Adjust the printhead pressure adjustment knob. * The release lever is not properly latched properly.

Problem	Possible Cause	Recovery Procedure
Missing printing on the left or right side of label	* Wrong label size setup.	* Set the correct label size.
Gray line on the blank label	* The print head is dirty. * The platen roller is dirty.	* Clean the print head. * Clean the platen roller.
Irregular printing	* The printer is in Hex Dump mode. * The RS-232 setting is incorrect.	* Turn off and on the printer to skip the dump mode. * Re-set the Rs-232 setting.
Label feeding is not stable (skewed) when printing	* The media guide does not touch the edge of the media.	* If the label is moving to the right side, please move the label guide to left. * If the label is moving to the left side, please move the label guide to right.
Skip labels when printing	* Label size is not specified properly. * Sensor sensitivity is not set properly. * The media sensor is covered with dust.	* Check if label size is setup correctly. * Calibrate the sensor by Auto Gap or Manual Gap options. * Clean the GAP/Black mark sensor with air.
Wrinkle Problem	* Printhead pressure is incorrect. * Ribbon installation is incorrect. * Media installation is incorrect. * Print density is incorrect. * Media feeding is incorrect.	* Please refer to Ribbon Flow Adjustment section. * Please set the suitable density to improve the print quality. * Adjust label guides to remove drag or interference.
RTC time is incorrect after printer reboot	*The battery has run down.	* Replace battery on the main board.
The left printout alignment is incorrect	* Wrong label size setup. * The parameter Shift X in LCD menu is incorrect.	* Set the correct label size. * Press [MENU] → [SELECT] x 3 → [DOWN] x 5 → [SELECT] to fine tune the parameter of Shift X.

Problem	Possible Cause	Recovery Procedure
<p>Incorrect small label printing position</p>	<ul style="list-style-type: none"> * Media sensor sensitivity is not set properly. * Label size is incorrect. * The parameter Shift Y in the LCD menu is incorrect. * The vertical offset setting in the driver is incorrect. 	<ul style="list-style-type: none"> * Calibrate the sensor sensitivity. * Set the correct label size and gap size. * Press [MENU] → [SELECT] x3 → [DOWN]x6 → [SELECT] to fine tune the parameter of Shift Y. * If using the label printing software, set the vertical offset in the driver.

Maintenance

Tools and Methods

Printer	Method	Interval
Print Head	<ol style="list-style-type: none"> 1. Always turn off the printer before cleaning the print head. 2. Allow the print head to cool for a minimum of one minute. 3. Use a (Head cleaner pen) or cotton swab and 99% isopropyl Alcohol to clean the print head surface. 	Clean the print head when changing a new label roll
	<p>The diagram illustrates the cleaning process of the print head. A 'Head Cleaner Pen' is used to clean the 'Print Head' surface. An 'Element' is also labeled. An inset box provides a magnified view of the 'Print Head' and 'Element'.</p>	
Platen Roller	<ol style="list-style-type: none"> 1. Turn the power off. 2. Rotate the platen roller and wipe it thoroughly with 99% alcohol and a cotton swab, or lint-free cloth. 	Clean the platen roller when Changing a new label roll
Tear Bar /Peel Bar	Use the lint-free cloth with 99% alcohol to wipe it.	As needed
Sensor	Compressed air or vacuum	Monthly
Exterior	Wipe it with water-dampened cloth	As needed
Interior	Brush or vacuum	As needed

Note:

- Do not touch print head by hand. If you touch it accidentally, please use alcohol to clean it.
- Please use 99% alcohol. DO NOT use medical alcohol, which may damage the printer head.
- Regularly clean the print head and supply sensors when changing a new ribbon to keep printer performance and extend printer life



Corporate Headquarters

803 Camarillo Springs Road, Suite-D
Camarillo, CA 93012
TEL: 800.215.9192
FAX: 805.484.5282
Web site: www.AMTDatasouth.com

Manufacturing/Service

5033 Sirona Drive, Suite-800
Charlotte, NC 28273
TEL: 800.476.2120
FAX: 704.525.6104
